

Surface Mount Fuses

Quick Index:

Series	Size	Current Rating (A)	Voltage Rating	Page		
SolidMatrix®	FA (Fast Acting)	1206	0.5, 0.75, 1.0, 1.5, 1.75, 2.0	63VDC	8	
			2.5, 3.0, 4.0, 5.0, 6.0, 7.0, 8.0	32VDC		
		0603	0.5, 0.75, 1.0, 1.5	63VDC	11	
			2.0, 2.5, 3.0, 3.5, 4.0, 5.0	32VDC		
			6.0	24VDC		
		0402	0.5, 0.75, 1.0, 1.5, 2.0, 3.0, 4.0	24VDC	14	
	SB (Slow Blow)	1206	1.0, 1.25, 1.5, 2.0	63VDC	17	
			2.5, 3.0, 3.5, 4.0, 4.5, 5.0	32VDC		
			5.5, 6.0, 7.0, 8.0	24VDC		
		0603	1.0, 1.5, 2.0, 2.5, 3.0, 3.5, 4.0, 4.5, 5.0, 6.0, 7.0, 8.0	32VDC	20	
			1206	0.5, 0.75	65VDC	23
				1.0, 1.5, 2.0	63VDC	
	2.5, 3.0, 3.5, 4.0, 4.5, 5.0	32VDC				
	6.0, 7.0, 8.0	24VDC				
	0603	1.0, 1.5, 2.0, 2.5, 3.0, 3.5, 4.0, 4.5, 5.0, 6.0, 7.0, 8.0	32VDC	26		
	HA (High Current)	1206	10, 12, 15, 20	24VDC	29	
HB (High Current)	1206	10, 12, 15, 20, 25, 30	24VDC	32		
HC (High Current)	1206	10, 12, 15, 20, 25, 30, 40	35VDC	35		
FF (Very Fast Acting)	0603	0.5, 0.75, 1.0, 1.25, 1.5, 1.75, 2.0, 2.5, 3.0, 3.5, 4.0, 4.5, 5.0	32VDC	38		
VH (Voltage High)	1206	2.5, 3.0, 3.5, 4.0, 4.5, 5.0	65VDC	41		
		6.0, 7.0, 8.0	48VDC			
TF-FUSE®	FF (Very Fast Acting)	0402	0.20, 0.25, 0.375, 0.50, 0.75, 1.00, 1.25, 1.50, 1.75, 2.00, 2.5, 3.00, 3.50, 4.00, 5.00	35VDC	46	
			0603	0.150, 0.200, 0.250, 0.375, 0.50, 0.75, 1.00, 1.25, 1.50		65VDC
		0603	1.75, 2.00, 2.50, 3.00, 3.50, 4.00, 5.00	35VDC	49	
	HI (High Inrush)	0603	0.50, 0.75, 1.00, 1.50	65VDC	52	
			2.00, 2.50, 3.00, 3.50, 4.00	35VDC		
AirMatrix®	AF	2410	0.5, 0.63, 0.75, 1.0, 1.25, 1.5, 2.0	250VAC/125VDC	58	
			2.5, 3.0, 3.15, 3.5, 4.0, 5.0, 6.3, 7.0, 8.0, 10.0	125VAC/DC		
			12.0, 15.0, 20.0	65VAC/DC		
		1206	1.50, 1.60, 2.00, 2.50, 3.00, 3.15, 3.50, 4.00	65VDC	62	
			5.00, 6.30, 7.00, 8.00, 10.0, 12.0, 15.0	32VDC		
			MF	2410		0.50, 0.63, 0.80, 1.00, 1.25, 1.60, 2.00
	1210	1.00, 1.50, 2.00, 2.50, 3.00	125VAC		70	

SolidMatrix® Surface Mount Fuses

Product Identification:

F 0603 FA 1000 V032 T M

(1) (2) (3) (4) (5) (6) (7)

- (1) **Product Code:** F—Chip Fuse
- (2) **Size Code:** Standard EIA Chip Sizes
- (3) **Series Code:** FA - Fast Acting, SB - Slow Blow,
HI - High Inrush, FF - Very Fast Acting, HB - High Current
- (4) **Current Rating Code:** 1000 - 1000 mA (For HB, 10 - 10A)
- (5) **Voltage Rating Code:** V032 - 32 VDC
- (6) **Package Code:** T - Tape & Reel, B - Bulk
- (7) **Marking Code:** M - With Marking

F 1206 HC 20A0 T M

(1) (2) (3) (4) (5) (6)

- (1) **Product Code:** F—Chip Fuse
- (2) **Size Code:** L x W (inch),
the first two digits-L (length),
the last two digits-W (width)
- (3) **Series Code:** HC Series
- (4) **Current Rating Code:** 20A0—20.0A
- (5) **Package Code:** T - Tape & Reel, B - Bulk

Recommended Land Pattern:

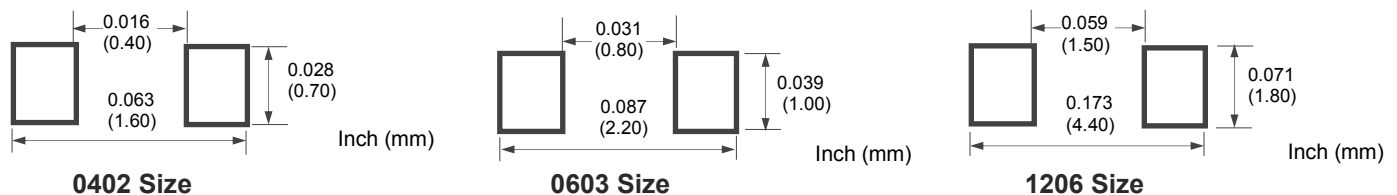

Environmental Tests:

No.	Test	Requirement	Test condition	Test reference
1	Soldering heat resistance	DCR change $\leq \pm 10\%$ No mechanical damage	One dip at 260°C for 60 seconds	MIL-STD-202 Method 210
2	Solderability	Minimum 95% coverage	One dip at 245°C for 5 seconds	MIL-STD-202 Method 208
3	Thermal shock	DCR change $\leq \pm 10\%$ No mechanical damage	100 cycles between -65°C and +125°C	MIL-STD-202 Method 107
4	Moisture resistance	DCR change $\leq \pm 15\%$ No excessive corrosion	10 cycles	MIL-STD-202 Method 106
5	Salt spray	DCR change $\leq \pm 10\%$ No excessive corrosion	48 hour exposure	MIL-STD-202 Method 101
6	Mechanical vibration	DCR change $\leq \pm 10\%$ No mechanical damage	0.4 " D.A. or 30 G between 5 – 3000 Hz	MIL-STD-202 Method 204
7	Mechanical shock	DCR change $\leq \pm 10\%$ No mechanical damage	1500 G, 0.5 ms, half-sine shocks	MIL-STD-202 Method 213
8	Life	No electrical "opens" during testing voltage drop change shall be less than $\pm 20\%$ of initial value	80% rated current (75% for < 1 A fuses) for 2000 hours at ambient temperature between +20°C and +30°C	Refer to AEM QIQ106

SolidMatrix® Surface Mount Fuses

Electrical Specification:

Clearing Time Characteristics:

Same as specified on the Short Form Data Sheet

Insulation Resistance after Opening:

20,000 ohms typical when cleared with rated voltage applied. Fuse clearing under low voltage conditions may result in lower after clearing insulation resistance values. (Note: Under normal fault conditions (low or rated voltage conditions), AEM SolidMatrix fuses provide sufficient after clearing insulation resistance values for circuit protection.)

Current Carrying Capacity:

100% rated current at +25°C ambient for 4 hours minimum when evaluated per MIL-PRF-23419

Interrupt Ratings:

Fuse Selection and Temperature De-rating Guideline:

The ambient temperature affects the current carrying capacity of fuses. When a fuse is operating at a temperature higher than 25°C, the fuse shall be “de-rated”.

To select a fuse from the catalog, the following rule may be followed:

Catalog Fuse Current Rating = Nominal Operating Current / 0.75 / % De-rating at the maximum operating temperature.

Example: At maximum operating temperature of 65°C, % De-rating is 90%. The nominal operating current is 4 A. The current rating for fuse selected from the catalog shall be: $4 / 0.75 / 90\% = 5.9$ or 6 A. Specifications and descriptions in this literature are as accurate as known at the time of publish, but are subject to change without notice.

Temperature De-Rating Curve for SolidMatrix Fuses

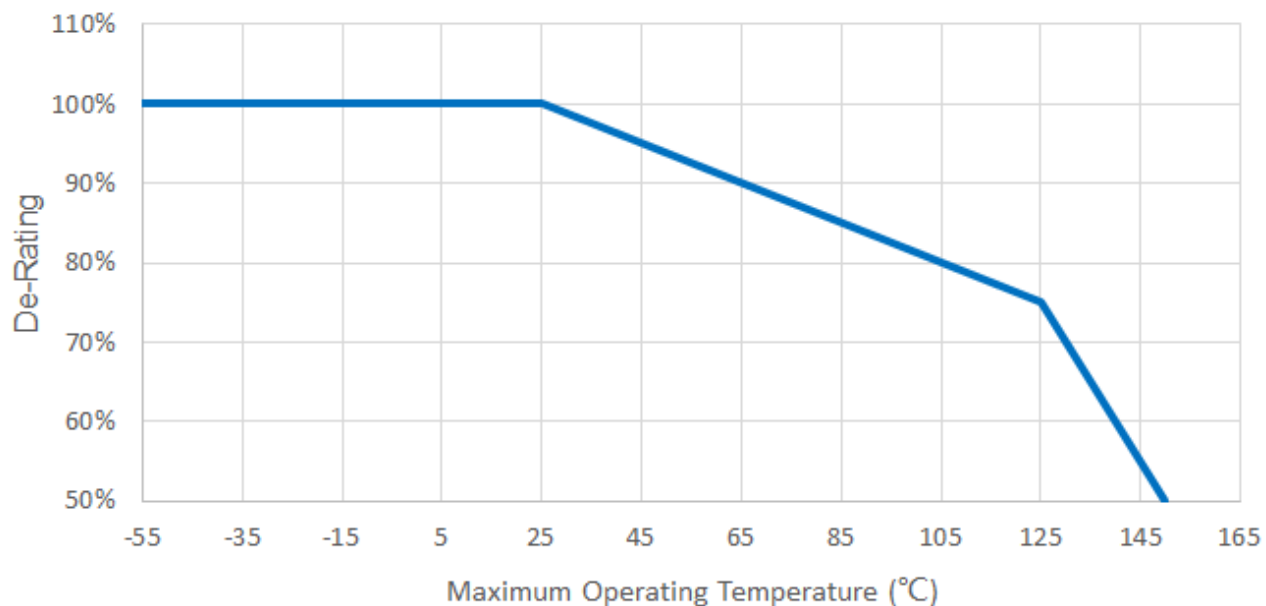

SolidMatrix® Surface Mount Fuses

Soldering Temperature Profile:

* Recommended Temperature Profile for Reflow Soldering

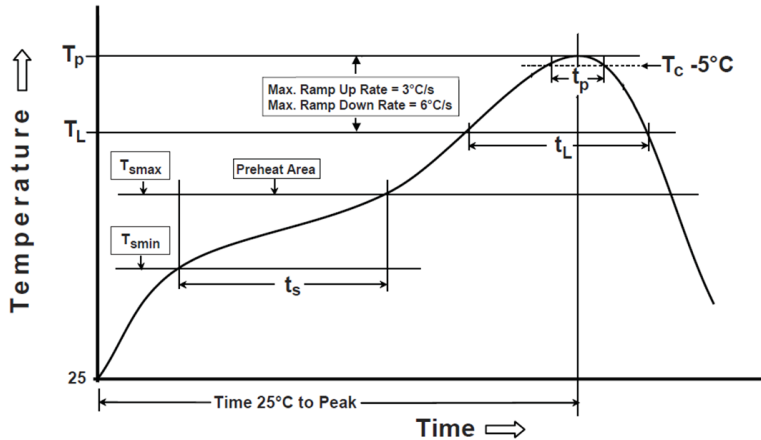

Profile Feature	Pb-Free Assembly
Preheat/Soak Temperature Min (T_{smin}) Temperature Max (T_{smax}) Time (t_s) from (T_{smin} to T_{smax})	150°C 200°C 60~120 seconds
Ramp-up rate (T_L to T_p)	3°C/second max.
Liquidous temperature (T_L) Time (t_L) maintained above T_L	217°C 60~150 seconds
Peak package body temperature (T_p)	260°C
Time (t_p)* within 5°C of the specified classification temperature (T_c)	30 seconds *
Ramp-down rate (T_p to T_L)	6°C/second max.
Time 25°C to peak temperature	8 minutes max.
* Tolerance for peak profile temperature (T_p) is defined as a supplier minimum and a user maximum	

* Recommended Temperature Profile for Wave Soldering

Recommended Temperature Profile for Wave Soldering

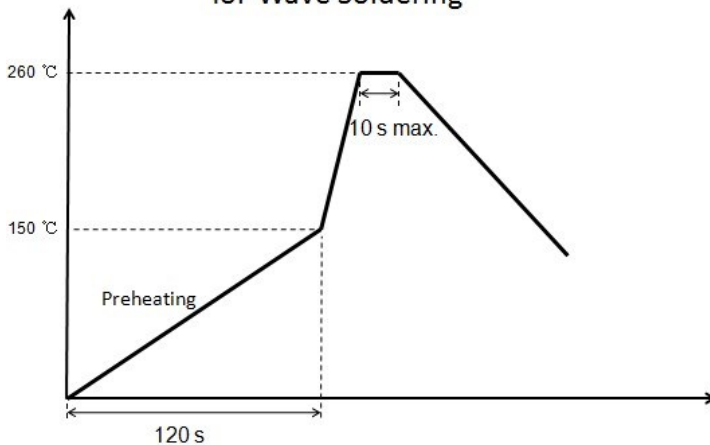

Notice: Wave Soldering is suitable for 1206 and 0603 size.

Packaging:

Chip Size	Parts on 7 inch (178 mm) Reel
0402 (1005)	10,000
0603 (1608)	4,000
0603FF (1608)	6,000
1206 (3216)	3,000

SolidMatrix[®] Surface Mount Fuses

FA Series (Fast Acting), 1206 Size



Clearing Time Characteristics:

% of current rating	Clearing time at 25°C
100%	4 hours min.
250%	5 seconds max.
400%	0.05 seconds max.

Agency Approval:

Recognized Under the Components Program of UL.
File Number: E232989.

Patents:

Patent numbers "US6,034,589", "US6,228,230", "US6,602,766", "US7,268,661 B2", "ZL00134544.3", "ZL02114719.1", "ZL200410104280.7", "ZL201020551360.8", "ZL201010299185.2", "ZL201220030614.0", "ZL201210020693.1".

Ordering Information:

Part Number	Current Rating (A)	Voltage Rating (VDC)	Interrupting Ratings	Nominal Cold DCR (Ω) ¹	Nominal I^2t (A^2s) ²	Marking Code ³
F1206FA0500V063TM	0.5	63	50 A at rated voltages	0.730	0.002	C
F1206FA0750V063TM	0.75	63		0.513	0.005	D
F1206FA1000V063TM	1.0	63		0.220	0.011	E
F1206FA1500V063TM	1.5	63		0.120	0.024	G
F1206FA1750V063TM	1.75	63		0.100	0.045	H
F1206FA2000V063TM	2.0	63		0.050	0.075	I
F1206FA2500V032TM	2.5	32		0.035	0.11	J
F1206FA3000V032TM	3.0	32	45 A at rated voltages	0.031	0.21	K
F1206FA4000V032TM	4.0	32		0.022	0.35	M
F1206FA5000V032TM	5.0	32		0.015	0.60	N
F1206FA6000V032TM	6.0	32		0.013	1.0	+
F1206FA7000V032TM	7.0	32		0.011	1.6	-
F1206FA8000V032TM	8.0	32		0.008	2.3	=

1. Measured at $\leq 10\%$ rated current and 25°C ambient.

2. Melting I^2t at 0.001 second pre-arcing time.

3. Black Marking Character Code.

Features:

- Multilayer monolithic structure with glass ceramic body and silver fusing element
- Silver termination with nickel and pure-tin solder plating, providing excellent solderability
- Compatible with both wave and reflow soldering processes
- Operating temperature range: -55°C to +150°C (with de-rating)

Shape and Dimensions:

Unit	Inch	mm
L	0.126 ± 0.008	3.20 ± 0.20
W	0.063 ± 0.008	1.60 ± 0.20
T	0.043 ± 0.008	1.10 ± 0.20
B	0.020 ± 0.010	0.51 ± 0.25

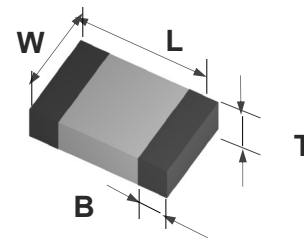

SolidMatrix[®] Surface Mount Fuses

FA Series (Fast Acting), 1206 Size

Average Pre-arcing Time Curves:

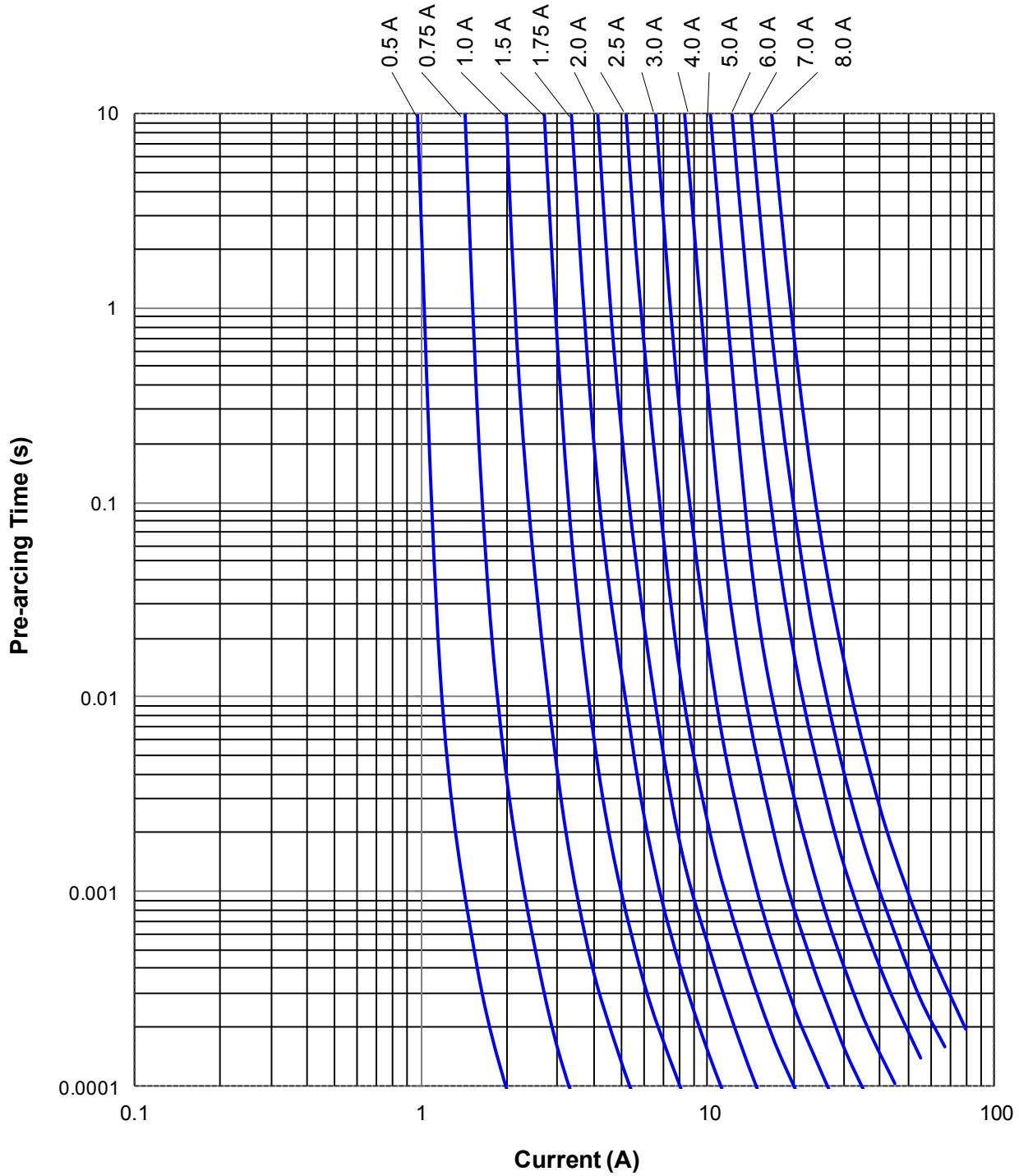

SolidMatrix[®] Surface Mount Fuses

FA Series (Fast Acting), 1206 Size

Average I^2t vs. t Curves:

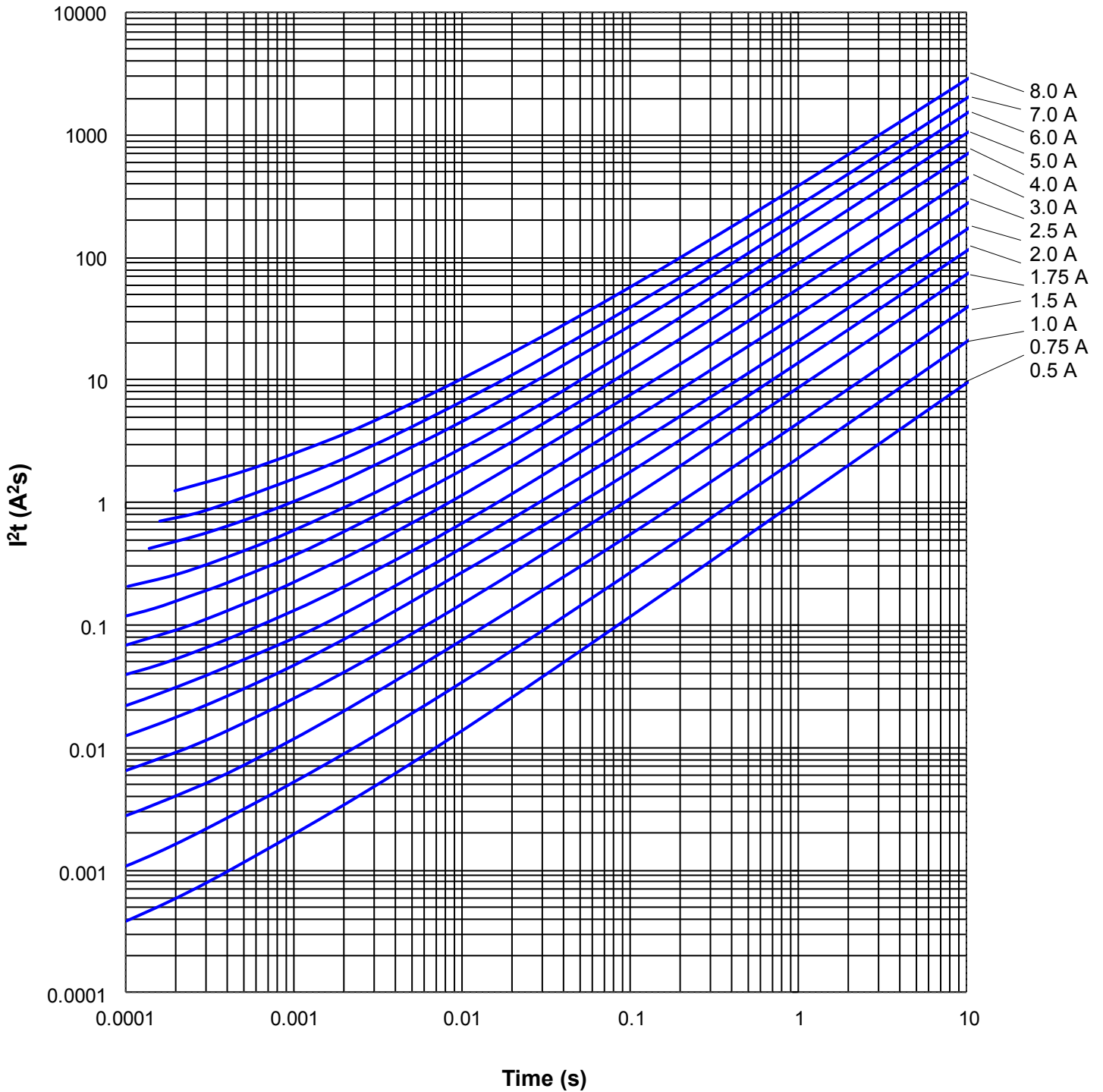

SolidMatrix® Surface Mount Fuses

FA Series (Fast Acting), 0603 Size



Features:

- Multilayer monolithic structure with glass ceramic body and silver fusing element
- Silver termination with nickel and pure-tin solder plating, providing excellent solderability
- Compatible with both wave and reflow soldering processes
- Operating temperature range: -55°C to +150°C (with de-rating)

Clearing Time Characteristics:

% of current rating	Clearing time at 25°C
100%	4 hours min.
250%	5 seconds max.
400%	0.05 seconds max.

Shape and Dimensions:

Unit	Inch	mm
L	0.063 ± 0.006	1.60 ± 0.15
W	0.031 ± 0.006	0.80 ± 0.15
T	0.031 ± 0.006	0.80 ± 0.15
B	0.014 ± 0.006	0.36 ± 0.15

Agency Approval:

Recognized Under the Components Program of UL.
File Number: E232989.

Patents:

Patent numbers "US6,034,589", "US6,602,766", "US7,268,661 B2", "ZL00134544.3", "ZL02114719.1", "ZL200410104280.7", "ZL201020551360.8", "ZL201010299185.2", "ZL201220030614.0", "ZL201210020693.1".

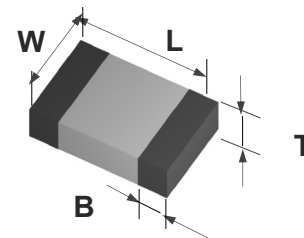

Ordering Information:

Part Number	Current Rating (A)	Voltage Rating (VDC)	Interrupting Ratings	Nominal Cold DCR (Ω) ¹	Nominal I ² t (A ² s) ²	Marking (Optional) ³
F0603FA0500V063TM	0.5	63	35 A at rated voltages	0.485	0.003	C
F0603FA0750V063TM	0.75	63		0.254	0.006	D
F0603FA1000V063TM	1.0	63		0.147	0.013	E
F0603FA1500V063TM	1.5	63		0.059	0.030	G
F0603FA2000V032TM	2.0	32		0.044	0.060	I
F0603FA2500V032TM	2.5	32		0.032	0.10	J
F0603FA3000V032TM	3.0	32		0.025	0.18	K
F0603FA3500V032TM	3.5	32		0.024	0.30	L
F0603FA4000V032TM	4.0	32		0.018	0.50	M
F0603FA5000V032TM	5.0	32		0.013	0.80	N
F0603FA6000V024TM	6.0	24		0.010	1.10	O

1. Measured at ≤ 10% rated current and 25°C ambient.

2. Melting I²t at 0.001 second pre-arcing time.

3. Black Marking Character Code.

SolidMatrix[®] Surface Mount Fuses

FA Series (Fast Acting), 0603 Size

Average Pre-arcing Time Curves:

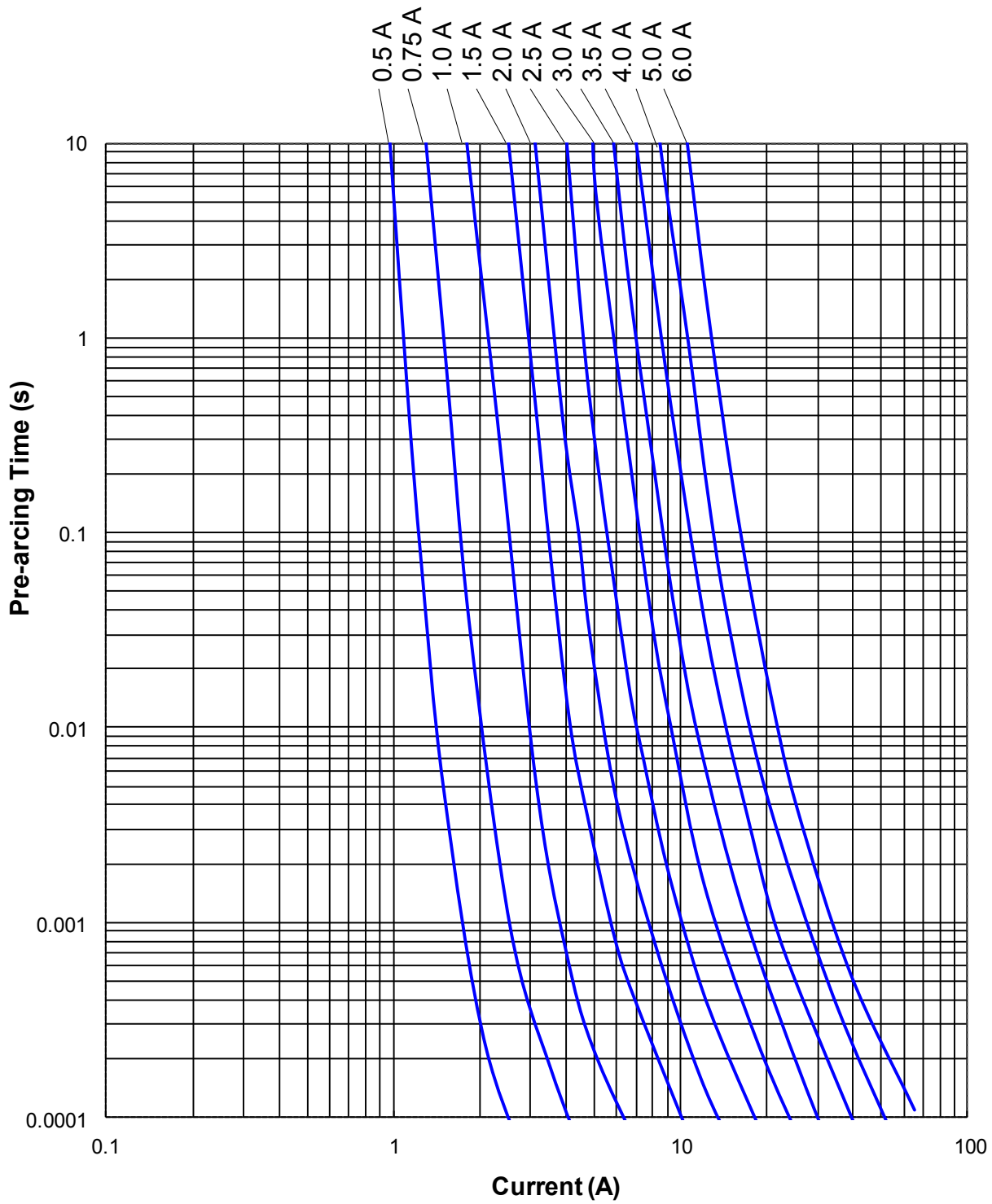

SolidMatrix[®] Surface Mount Fuses

FA Series (Fast Acting), 0603 Size

Average I^2t vs. t Curves:

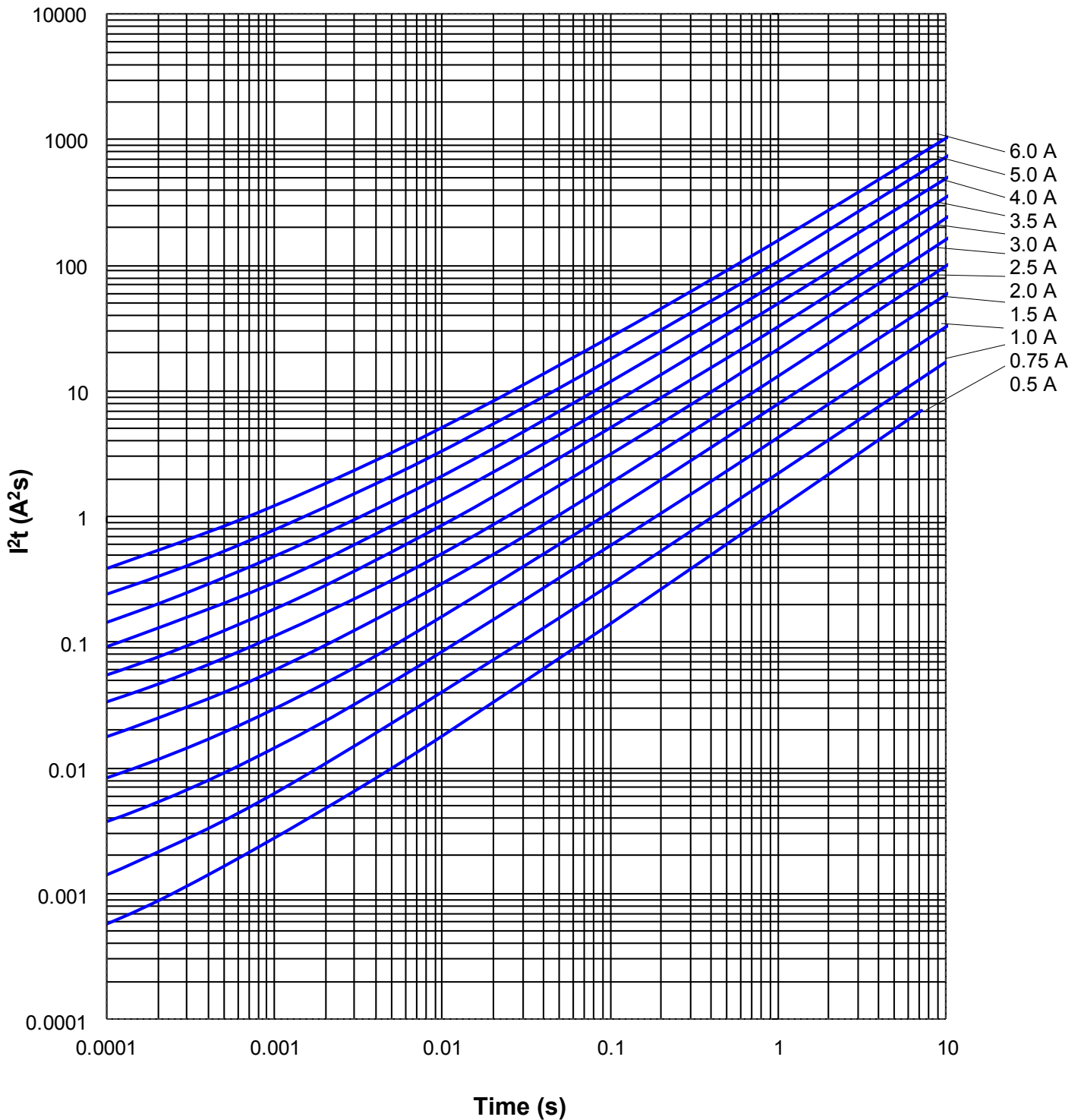

SolidMatrix® Surface Mount Fuses

FA Series (Fast Acting), 0402 Size



Features:

- Multilayer monolithic structure with glass ceramic body and silver fusing element
- Silver termination with nickel and pure-tin solder plating, providing excellent solderability
- Compatible with both wave and reflow soldering processes
- Operating temperature range: -55°C to +150°C (with de-rating)

Clearing Time Characteristics:

% of current rating	Clearing time at 25°C
100%	4 hours min.
250%	5 seconds max.
400%	0.05 seconds max.

Shape and Dimensions:

Unit	Inch	mm
L	0.039 ± 0.004	1.00 ± 0.10
W	0.020 ± 0.004	0.51 ± 0.10
T	0.020 ± 0.004	0.51 ± 0.10
B	0.010 ± 0.004	0.25 ± 0.10

Agency Approval:

Recognized Under the Components Program of UL.
File Number: E232989.

Patents:

Patent numbers "US6,034,589", "US6,602,766", "US7,268,661 B2", "ZL00134544.3", "ZL02114719.1", "ZL200410104280.7", "ZL201020551360.8", "ZL201010299185.2", "ZL201220030614.0", "ZL201210020693.1".

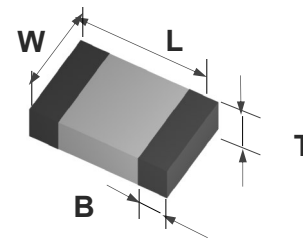

Ordering Information:

Part Number	Current Rating (A)	Voltage Rating (VDC)	Interrupting Ratings	Nominal Cold DCR (Ω) ¹	Nominal I^2t (A^2s) ²
F0402FA0500V024T	0.5	24	35 A at rated voltage	0.380	0.004
F0402FA0750V024T	0.75	24		0.210	0.007
F0402FA1000V024T	1.0	24		0.120	0.014
F0402FA1500V024T	1.5	24		0.056	0.050
F0402FA2000V024T	2.0	24		0.035	0.070
F0402FA3000V024T	3.0	24		0.021	0.11
F0402FA4000V024T	4.0	24		0.014	0.21

1. Measured at $\leq 10\%$ rated current and 25°C ambient.
2. Melting I^2t at 0.001 second pre-arcing time.

SolidMatrix[®] Surface Mount Fuses

FA Series (Fast Acting), 0402 Size

Average Pre-arcing Time Curves:

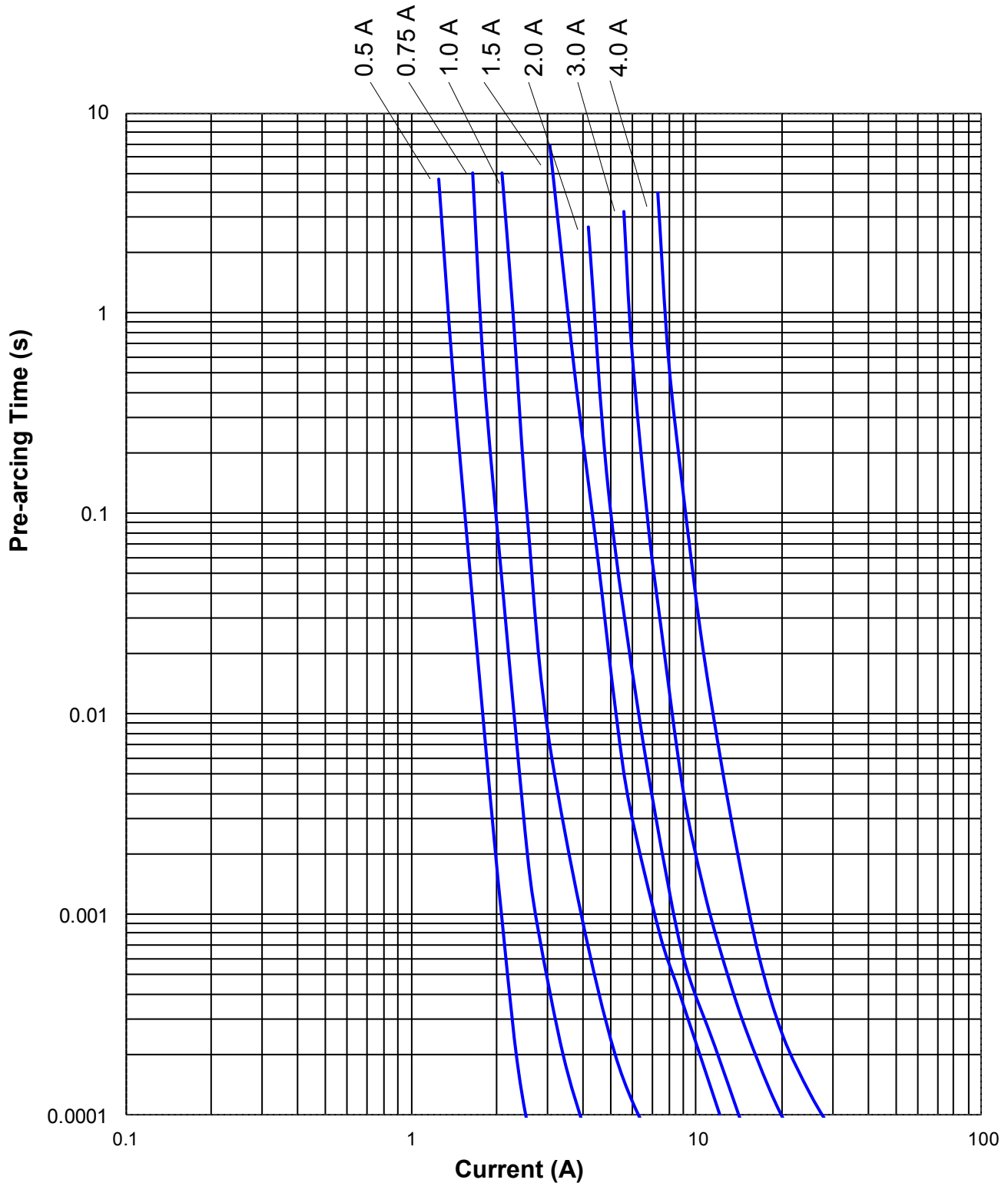

SolidMatrix[®] Surface Mount Fuses

FA Series (Fast Acting), 0402 Size

Average I^2t vs. t Curves:

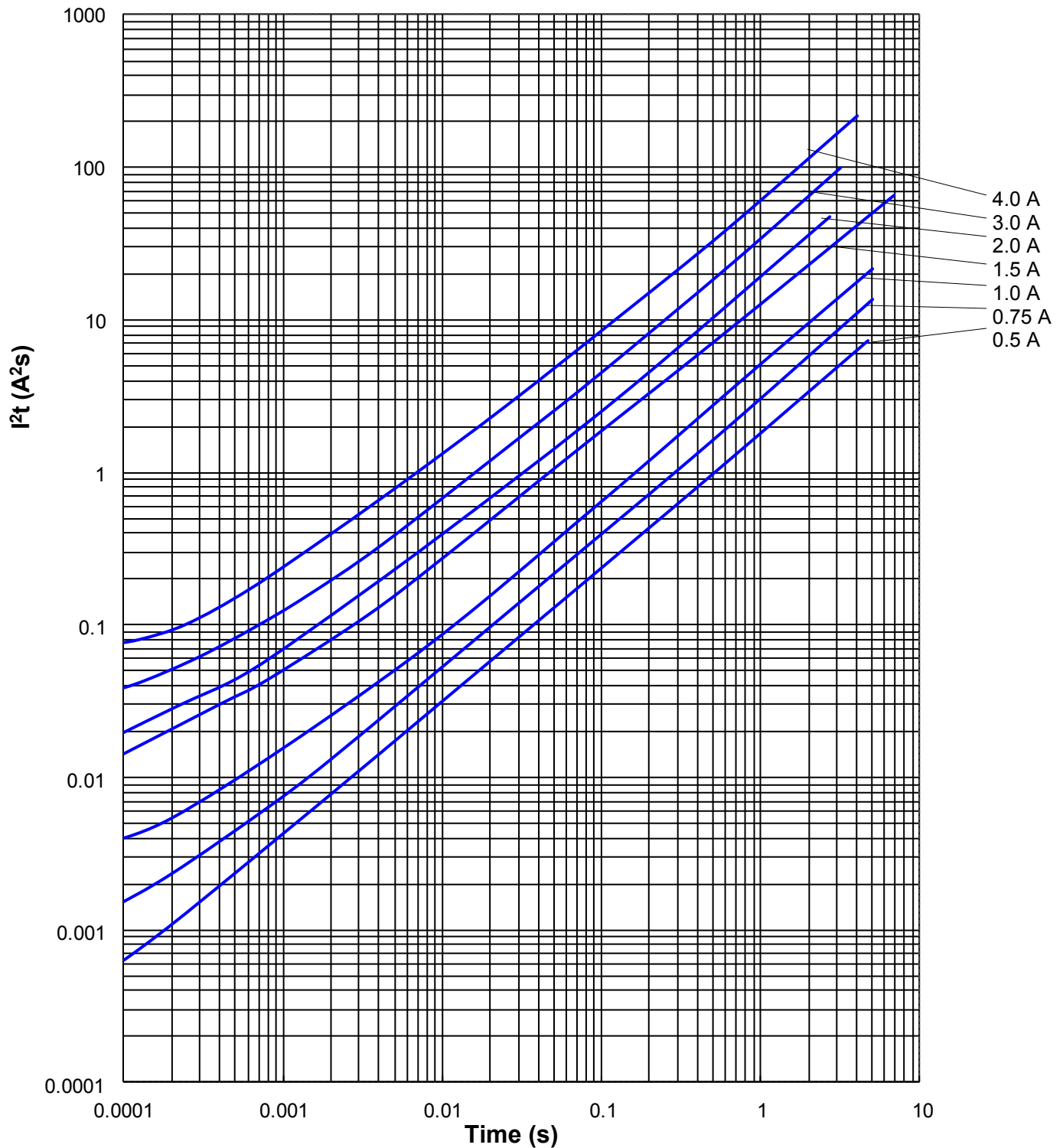

SolidMatrix® Surface Mount Fuses

SB Series (Slow Blow), 1206 Size



Features:

- High inrush current withstanding capability
- Multilayer monolithic structure with glass ceramic body and silver fusing element
- Silver termination with nickel and pure-tin solder plating, providing excellent solderability
- Compatible with both wave and reflow soldering processes
- Operating temperature range: -55°C to +150°C (with de-rating)

Clearing Time Characteristics:

% of current rating	Clearing time at 25°C	
	min.	max.
100%	4 hours	
200%	1 second	120 seconds
300%	0.1 seconds	3 seconds
800%	0.002 seconds	0.05 seconds

Shape and Dimensions:

Unit	Inch	mm
L	0.126 ± 0.008	3.20 ± 0.20
W	0.063 ± 0.008	1.60 ± 0.20
T	0.038 ± 0.008	0.97 ± 0.20
B	0.020 ± 0.010	0.51 ± 0.25

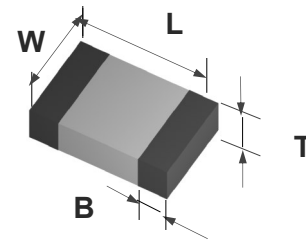

Agency Approval:

Recognized Under the Components Program of UL.
File Number: E232989.

Patents:

Patent numbers "US6,034,589", "US6,602,766", "US7,268,661 B2", "ZL00134544.3", "ZL02114719.1", "ZL200410104280.7", "ZL201020551352.3", "ZL201020551360.8", "ZL201010299185.2", "ZL201220030614.0", "ZL201210020693.1".

Ordering Information:

Part Number	Current Rating (A)	Voltage Rating (VDC)	Interrupting Ratings	Nominal Cold DCR (Ω) ¹	Nominal I ² t (A ² s) ²	Marking Code ³
F1206SB1000V063TM	1.0	63	50 A at rated voltages	0.360	0.11	E
F1206SB1250V063TM	1.25	63		0.200	0.22	F
F1206SB1500V063TM	1.5	63		0.150	0.23	G
F1206SB2000V063TM	2.0	63		0.088	0.63	I
F1206SB2500V032TM	2.5	32		0.065	0.90	J
F1206SB3000V032TM	3.0	32		0.034	1.20	K
F1206SB3500V032TM	3.5	32		0.028	1.60	L
F1206SB4000V032TM	4.0	32		0.024	2.20	M
F1206SB4500V032TM	4.5	32		0.020	3.60	T
F1206SB5000V032TM	5.0	32		0.018	5.30	N
F1206SB5500V024TM	5.5	24		0.014	6.40	U
F1206SB6000V024TM	6.0	24		60 A at rated voltage	0.011	8.50
F1206SB7000V024TM	7.0	24	0.010		10.0	P
F1206SB8000V024TM	8.0	24	0.009		16.9	R

1. Measured at $\leq 10\%$ rated current and 25°C ambient.

2. Melting I²t at 0.001 second pre-arcing time.

3. Red Marking Character Code.

SolidMatrix[®] Surface Mount Fuses

SB Series (Slow Blow), 1206 Size

Average Pre-arcing Time Curves:

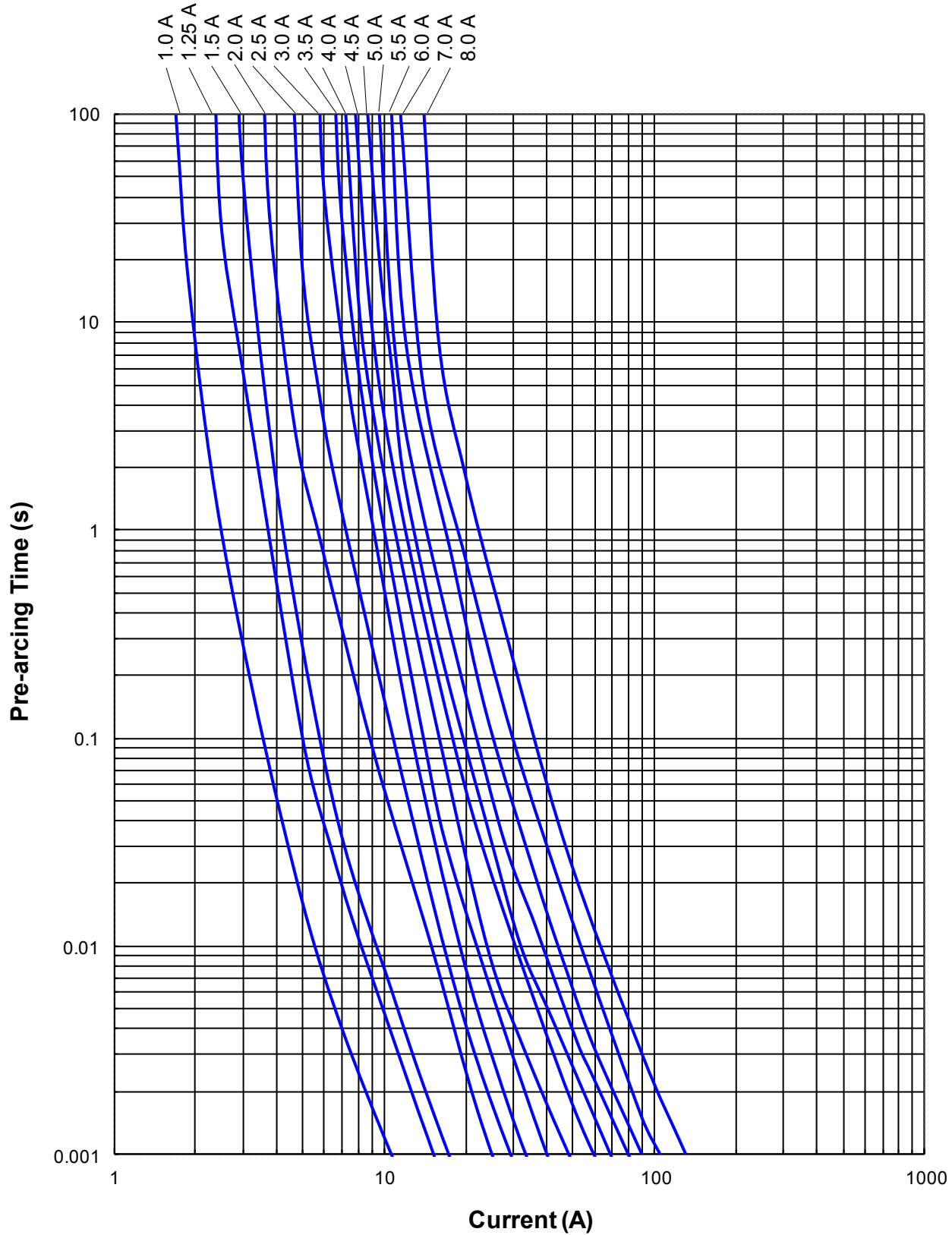

SolidMatrix[®] Surface Mount Fuses

SB Series (Slow Blow), 1206 Size

Average I^2t vs. t Curves:

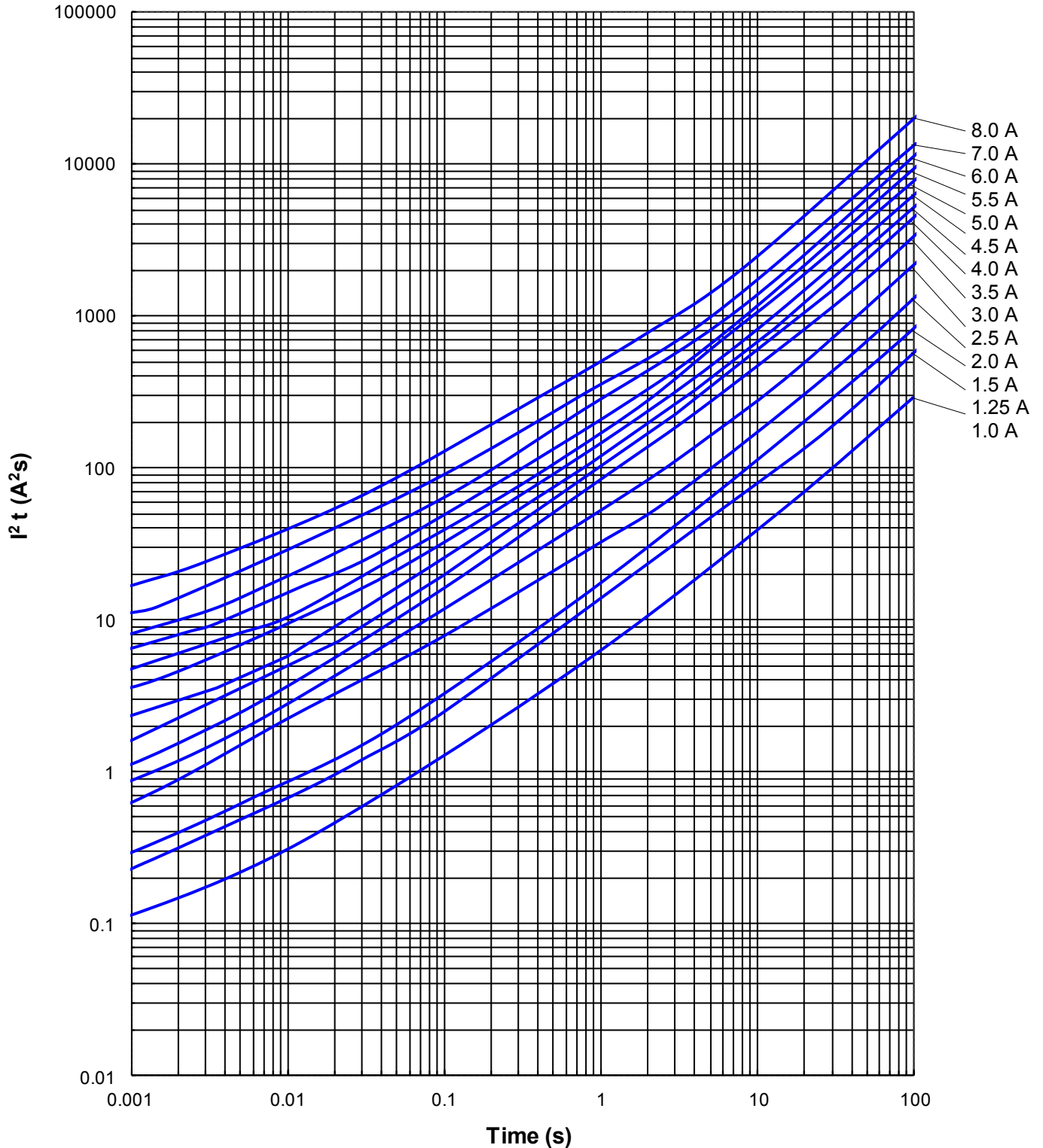

SolidMatrix® Surface Mount Fuses

SB Series (Slow Blow), 0603 Size



Features:

- High inrush current withstanding capability
- Ceramic Monolithic structure
- Silver fusing element and silver termination with nickel and tin plating
- Symmetrical design with marking on both sides (optional)
- Operating temperature range: -55°C to +150°C (with de-rating)

Clearing Time Characteristics:

% of Current Rating	Clearing time at 25°C	
	4 hours min.	120 seconds max.
100%	4 hours min.	
200%	1 second min.	120 seconds max.
300%	0.1 seconds min.	3 seconds max.
800% (1 A - 1.5 A)	0.0005 seconds min.	0.05 seconds max.
800% (2 A - 8 A)	0.001 seconds min.	0.05 seconds max.

Shape and Dimensions:

Unit	Inch	mm
L	0.063 ± 0.006	1.60 ± 0.15
W	0.031 ± 0.006	0.80 ± 0.15
T	0.031 ± 0.006	0.80 ± 0.15
B	0.014 ± 0.006	0.36 ± 0.15

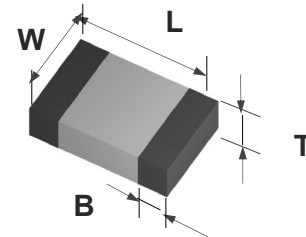

Agency Approval:

Recognized Under the Components Program of UL.
File Number: E232989.

Patents:

Patent numbers "US6,034,589", "US6,602,766", "US7,268,661 B2", "ZL00134544.3", "ZL02114719.1", "ZL200410104280.7", "ZL201020551352.3", "ZL201020551360.8", "ZL201010299185.2", "ZL201220030614.0", "ZL201210020693.1.

Ordering Information:

Part Number	Current Rating (A)	Voltage Rating (VDC)	Interrupting Ratings	Nominal Cold DCR(Ω) ¹	Nominal I ² t (A ² s) ²	Marking (Optional) ³
F0603SB1000V032TM	1.0	32	50 A at rated voltage	0.200	0.093	E
F0603SB1500V032TM	1.5	32		0.100	0.18	G
F0603SB2000V032TM	2.0	32		0.052	0.32	I
F0603SB2500V032TM	2.5	32		0.041	0.63	J
F0603SB3000V032TM	3.0	32		0.031	0.87	K
F0603SB3500V032TM	3.5	32		0.021	1.20	L
F0603SB4000V032TM	4.0	32		0.017	2.30	M
F0603SB4500V032TM	4.5	32		0.015	2.70	T
F0603SB5000V032TM	5.0	32		0.013	3.20	N
F0603SB6000V032TM	6.0	32		80 A at rated voltage	0.010	4.00
F0603SB7000V032TM	7.0	32	0.008		5.00	P
F0603SB8000V032TM	8.0	32	0.006		7.00	R

1. Measured at ≤ 10% rated current and 25°C ambient. 2. Melting I²t at 0.001 second pre-arcing time. 3. Red Marking Character Code.

SolidMatrix[®] Surface Mount Fuses

SB Series (Slow Blow), 0603 Size

Average Pre-arcing Time Curves:

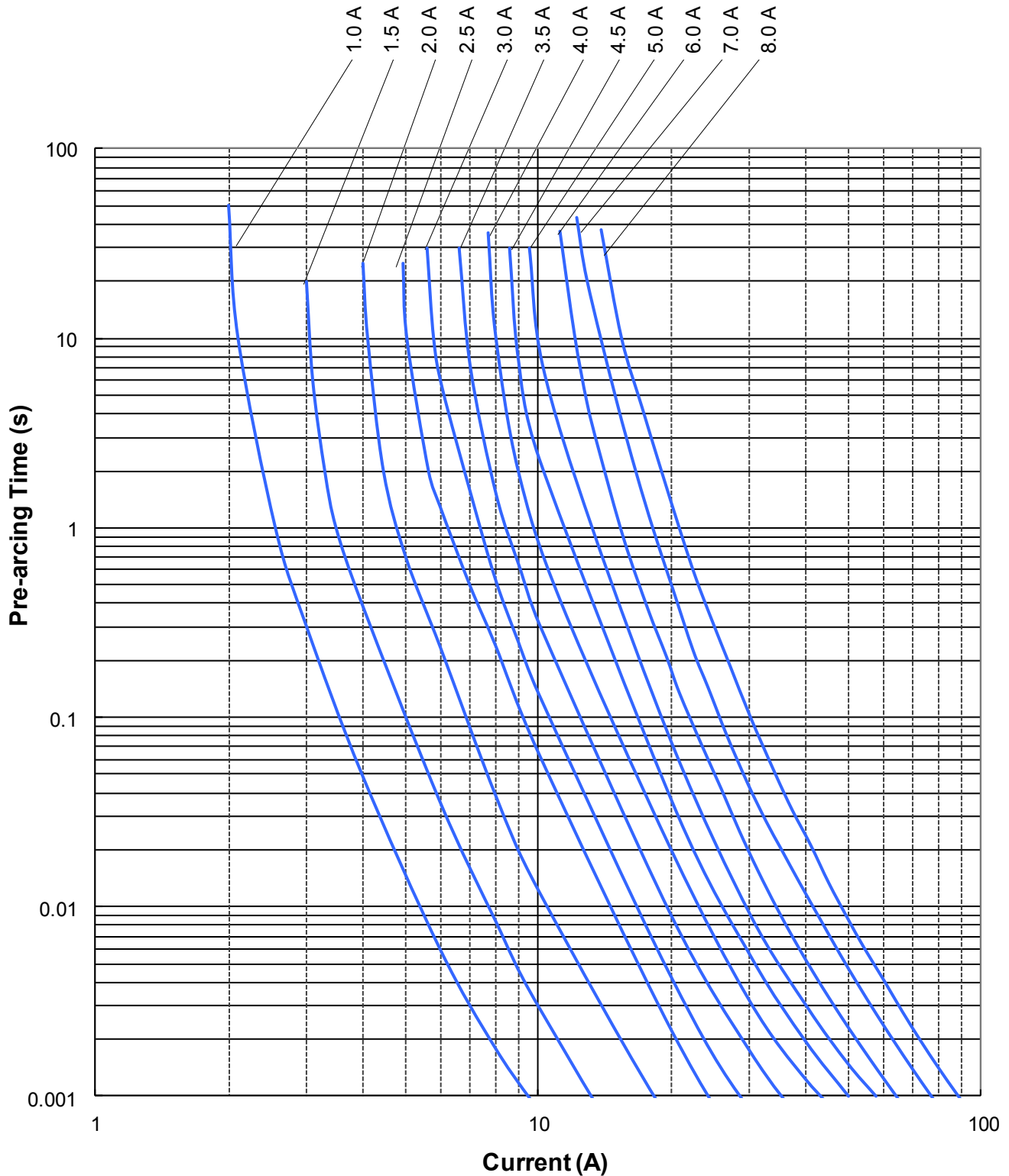

SolidMatrix[®] Surface Mount Fuses

SB Series (Slow Blow), 0603 Size

Average I^2t vs. t Curves:

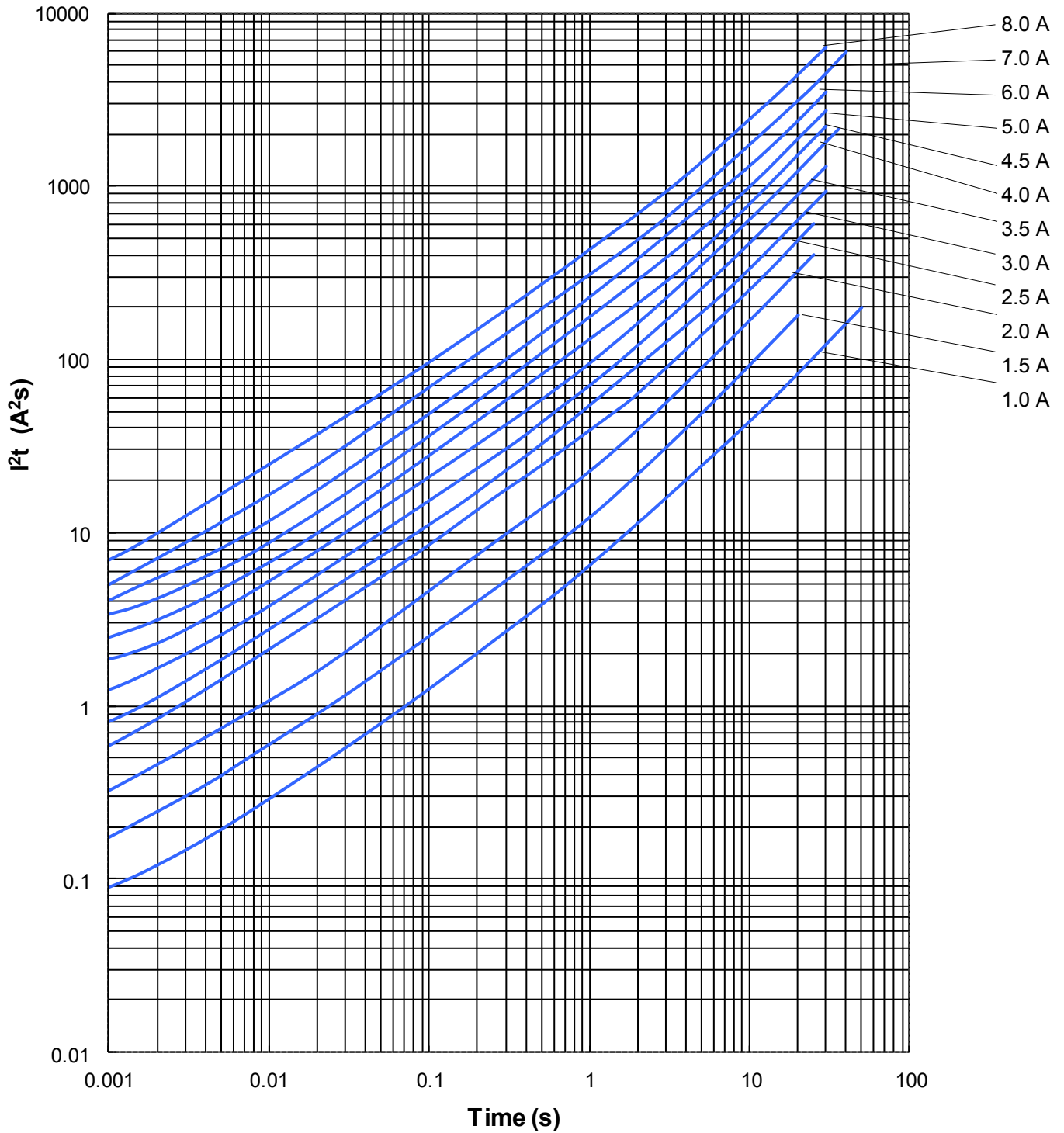

SolidMatrix® Surface Mount Fuses

HI Series (High Inrush), 1206 Size



Features:

- High inrush current withstanding capability
- Ceramic Monolithic structure
- Silver fusing element and silver termination with nickel and tin plating
- Symmetrical design with marking on both sides (optional)
- Operating temperature range: -55°C to +150°C (with de-rating)

Clearing Time Characteristics:

% of Current Rating	Clearing time at 25°C	
100%	4 hours min.	
200% (1.0 A -8.0A)	1 second min.	60 seconds max.
350% (0.5 A -0.75 A)		5 seconds max.
1000% (0.5 A -5.0 A)	0.0002 seconds min.	0.02 seconds max.
1000% (6.0 A -8.0 A)	0.0002 seconds min.	0.04 seconds max.

Shape and Dimensions:

Unit	Inch	mm
L	0.126 ± 0.008	3.20 ± 0.20
W	0.063 ± 0.008	1.60 ± 0.20
T	0.038 ± 0.008	0.97 ± 0.20
B	0.020 ± 0.010	0.51 ± 0.25

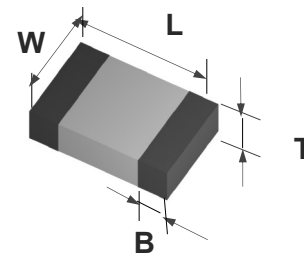

Agency Approval:

Recognized Under the Components Program of UL.
File Number: E232989.

Patents:

Patent numbers "US6,034,589", "US6,602,766", "US7,268,661 B2", "ZL00134544.3", "ZL02114719.1", "ZL200410104280.7", "ZL201020551360.8", "ZL201010299185.2", "ZL201220030614.0", "ZL201210020693.1".

Ordering Information:

Part Number	Current Rating (A)	Voltage Rating (VDC)	Interrupting Ratings	Nominal Cold DCR (Ω) ¹	Nominal I ² t (A ² s) ²	Marking Code ³
F1206HI0500V065TM	0.5	65	50 A at rated voltages	1.000	0.035	C
F1206HI0750V065TM	0.75	65		0.420	0.10	D
F1206HI1000V063TM	1.0	63		0.340	0.11	E
F1206HI1500V063TM	1.5	63		0.150	0.33	G
F1206HI2000V063TM	2.0	63		0.090	0.80	I
F1206HI2500V032TM	2.5	32		0.065	1.19	J
F1206HI3000V032TM	3.0	32		0.035	1.35	K
F1206HI3500V032TM	3.5	32		0.029	1.84	L
F1206HI4000V032TM	4.0	32		0.023	2.74	M
F1206HI4500V032TM	4.5	32		0.021	3.20	T
F1206HI5000V032TM	5.0	32		0.017	5.50	N
F1206HI6000V024TM	6.0	24		80 A at rated voltage	0.013	12.5
F1206HI7000V024TM	7.0	24	0.010		30.0	P
F1206HI8000V024TM	8.0	24	0.009		60.0	R

1. Measured at ≤ 10% rated current and 25°C ambient. 2. Melting I²t at 1000% of current rating. 3. Green Marking Character Code.

SolidMatrix[®] Surface Mount Fuses

HI Series (High Inrush), 1206 Size

Average Pre-arcing Time Curves:

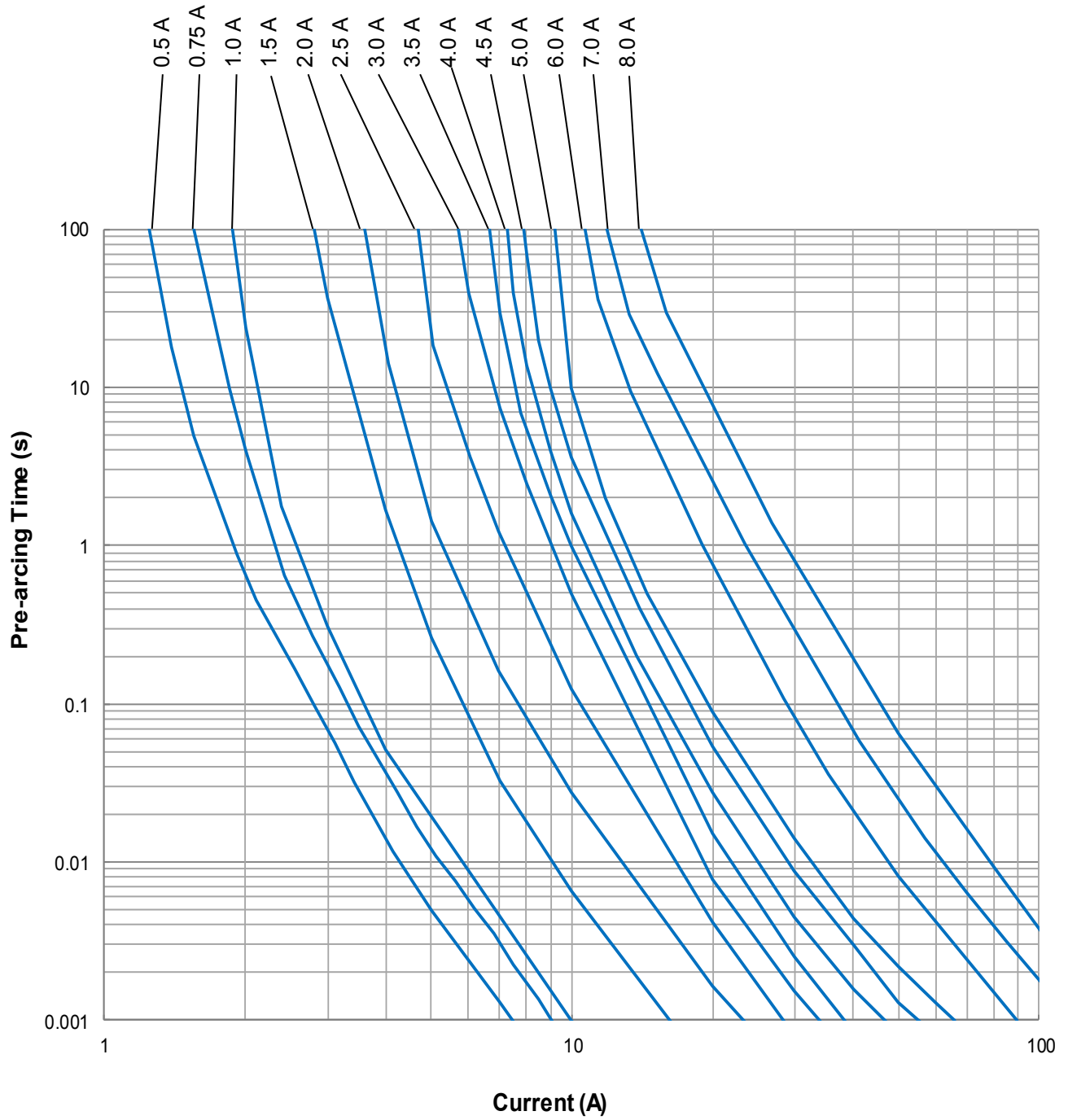

SolidMatrix[®] Surface Mount Fuses

HI Series (High Inrush), 1206 Size

Average I^2t vs. t Curves:

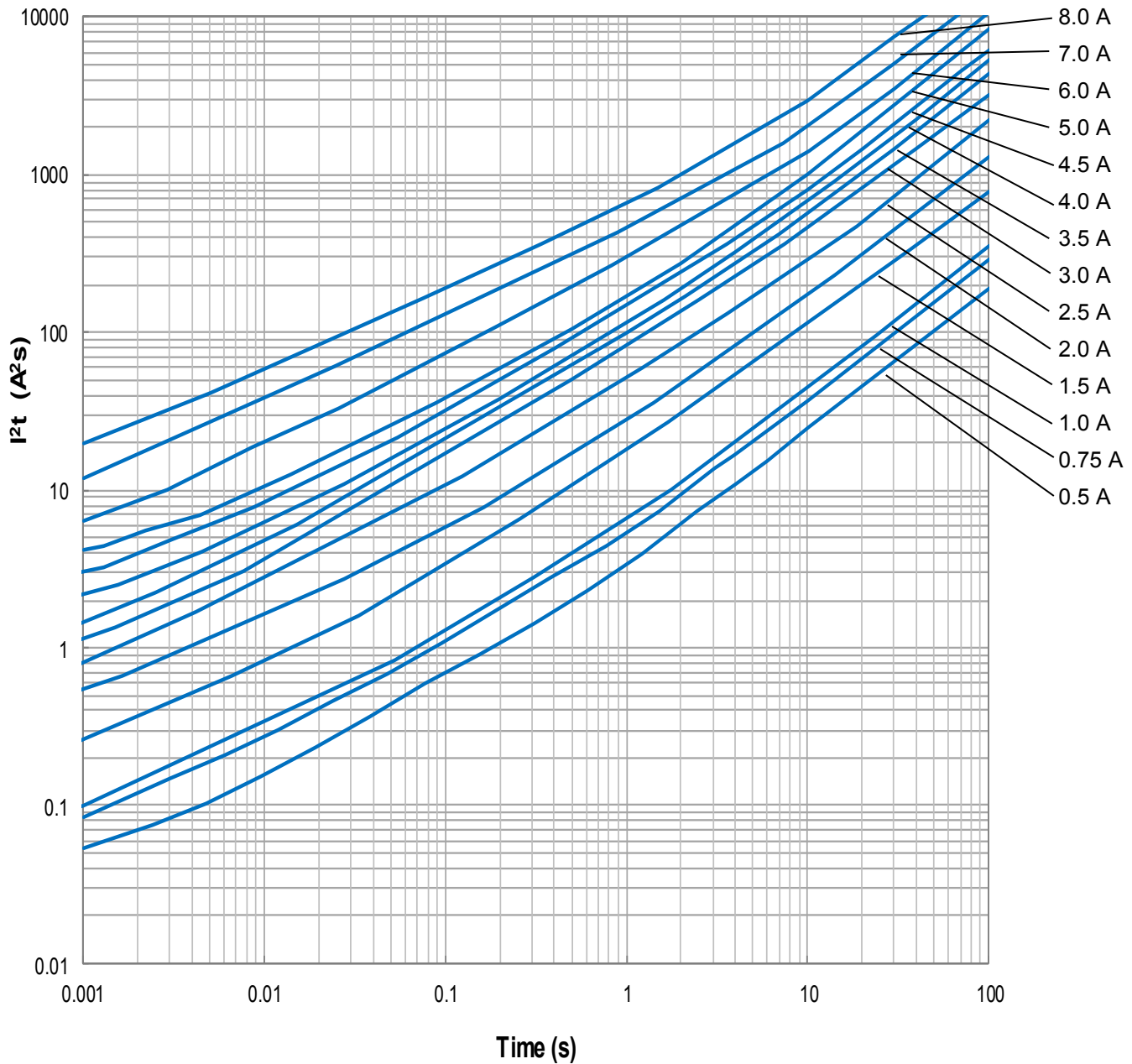

SolidMatrix[®] Surface Mount Fuses

HI Series (High Inrush), 0603 Size



Features:

- High inrush current withstanding capability
- Ceramic Monolithic structure
- Silver fusing element and silver termination with nickel and tin plating
- Symmetrical design with marking on both sides (optional)
- Operating temperature range: -55°C to +150°C (with de-rating)

Clearing Time Characteristics:

% of Current Rating	Clearing time at 25°C	
	4 hours min.	60 seconds max.
100%	4 hours min.	
200%	1 second min.	60 seconds max.
1000% (1-5A)	0.0002 seconds min.	0.02 seconds max.

Shape and Dimensions:

Unit	Inch	mm
L	0.063 ± 0.006	1.60 ± 0.15
W	0.031 ± 0.006	0.80 ± 0.15
T	0.031 ± 0.006	0.80 ± 0.15
B	0.014 ± 0.006	0.36 ± 0.15

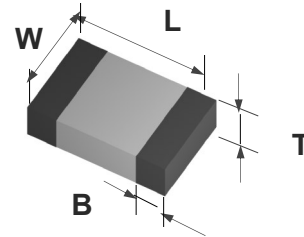

Agency Approval:

Recognized Under the Components Program of UL.
File Number: E232989.

Patents:

Patent numbers "US6,034,589", "US6,602,766", "US7,268,661 B2", "ZL00134544.3", "ZL02114719.1", "ZL200410104280.7", "ZL201020551360.8", "ZL201010299185.2", "ZL201220030614.0", "ZL201210020693.1".

Ordering Information:

Part Number	Current Rating (A)	Voltage Rating (VDC)	Interrupting Ratings	Nominal Cold DCR(Ω) ¹	Nominal I ² t (A ² s) ²	Marking (Optional) ³
F0603HI1000V032TM	1.0	32	50 A at rated voltage	0.210	0.08	E
F0603HI1500V032TM	1.5	32		0.101	0.11	G
F0603HI2000V032TM	2.0	32		0.057	0.24	I
F0603HI2500V032TM	2.5	32		0.042	0.56	J
F0603HI3000V032TM	3.0	32		0.030	0.72	K
F0603HI3500V032TM	3.5	32		0.022	1.10	L
F0603HI4000V032TM	4.0	32		0.018	2.08	M
F0603HI4500V032TM	4.5	32		0.014	2.63	T
F0603HI5000V032TM	5.0	32		0.013	3.25	N
F0603HI6000V032TM	6.0	32	70 A at rated voltage	0.010	4.00	O
F0603HI7000V032TM	7.0	32	80 A at rated voltage	0.008	5.00	P
F0603HI8000V032TM	8.0	32		0.006	7.00	R

1. Measured at ≤ 10% rated current and 25°C ambient.

2. Melting I²t at 1000% of current rating.

3. Green Marking Character Code.

SolidMatrix[®] Surface Mount Fuses HI Series (High Inrush), 0603 Size

Average Pre-arcing Time Curves:

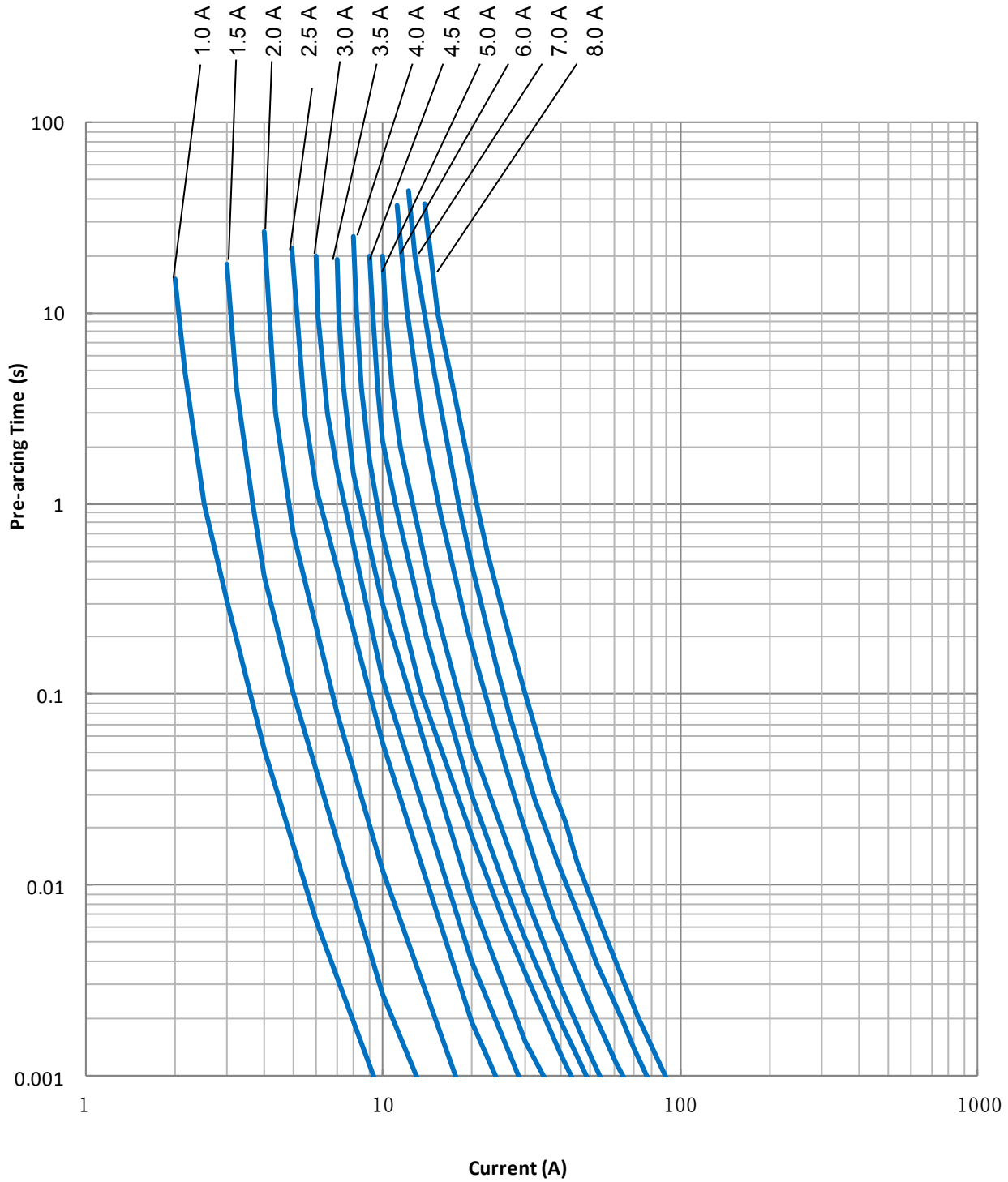

SolidMatrix[®] Surface Mount Fuses

HI Series (High Inrush), 0603 Size

Average I^2t vs. t Curves:

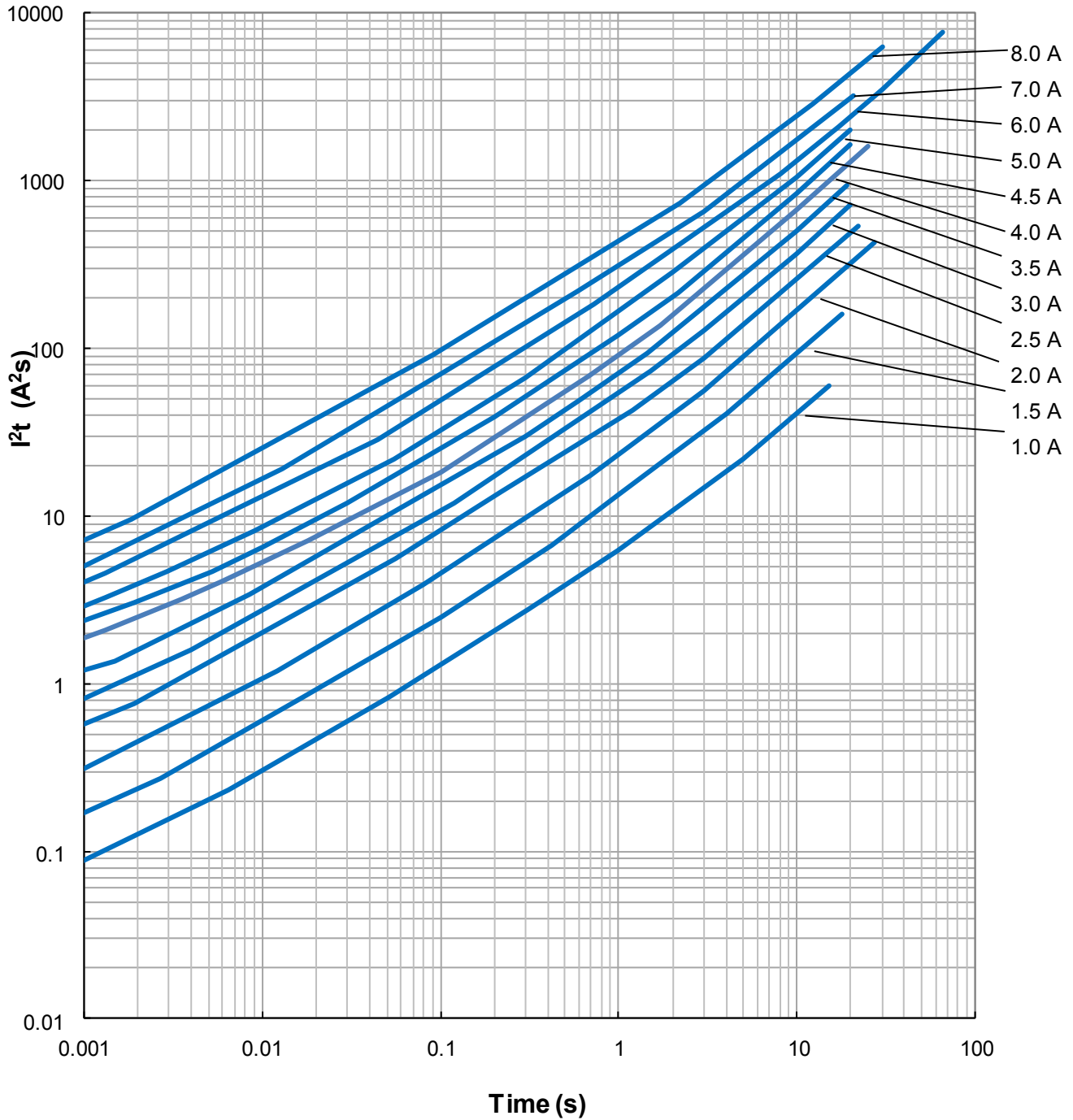

SolidMatrix® Surface Mount Fuses

HA Series (High Current), 1206 Size



Features:

- Special products for high current rating applications
- Glass ceramic monolithic structure
- Silver fusing element and silver termination with nickel and tin plating
- RoHS compliant and lead-free materials
- Superior arc suppression capability
- High current ratings
- Symmetrical design with marking on both sides (optional)
- Operating temperature range: -55°C to 150°C (with de-rating)

Clearing Time Characteristics:

% of current rating	Clearing time at 25°C
100%	4 hours min.
250%	5 seconds max.

Agency Approval:

Recognized Under the Components Program of UL.
File Number: E232989.

Patents:

Patent numbers "US6,034,589", "US6,602,766", "US6,844,278", "ZL00134544.3", "ZL02114719.1", "ZL201020551360.8", "ZL201010299185.2", "ZL201220030614.0", "ZL201210020693.1".

Shape and Dimensions:

Unit	Inch	mm
L	0.126 ± 0.008	3.20 ± 0.20
W	0.063 ± 0.008	1.60 ± 0.20
T	0.038 ± 0.008	0.97 ± 0.20
B	0.020 ± 0.010	0.51 ± 0.25

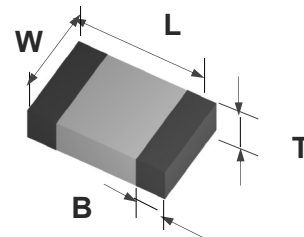

Ordering Information:

Part Number	Current Rating (A)	Voltage Rating (VDC)	Interrupting Ratings	Nominal Cold DCR (Ω) ¹	Nominal I^2t (A^2s) ²	Marking Code ³
F1206HA10V024TM	10	24	100A@24Vdc	0.010	9	Q
F1206HA12V024TM	12	24		0.008	14	X
F1206HA15V024TM	15	24		0.005	26	Y
F1206HA20V024TM	20	24		0.003	56	Z

1. Measured at $\leq 10\%$ rated current and 25°C ambient.
2. Melting I^2t at 0.001 second pre-arcing time
3. Black Marking Character Code.

SolidMatrix[®] Surface Mount Fuses

HA Series (High Current), 1206 Size

Average Pre-arcing Time Curves:

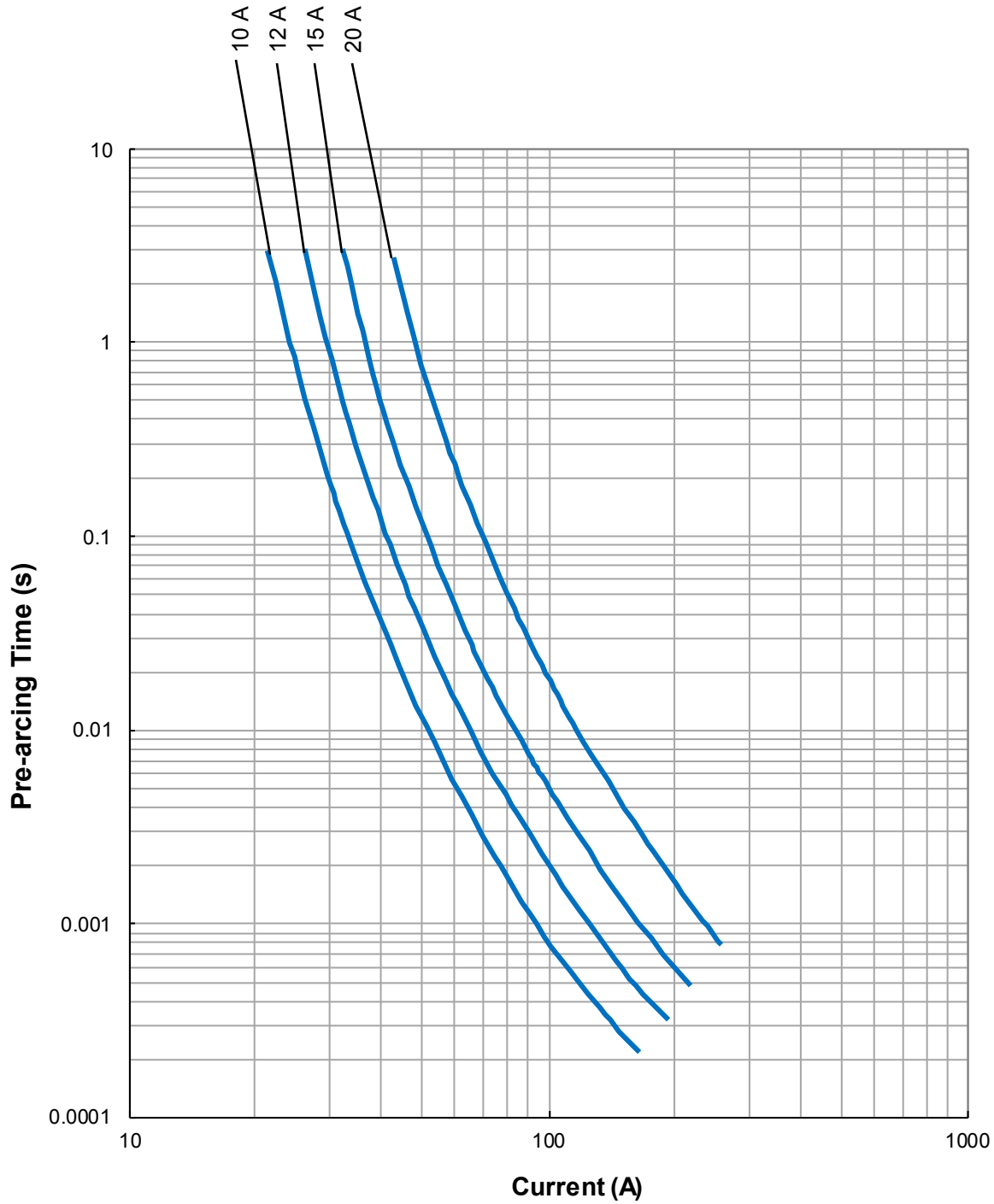

SolidMatrix[®] Surface Mount Fuses
HA Series (High Current), 1206 Size

Average I^2t vs. t Curves:

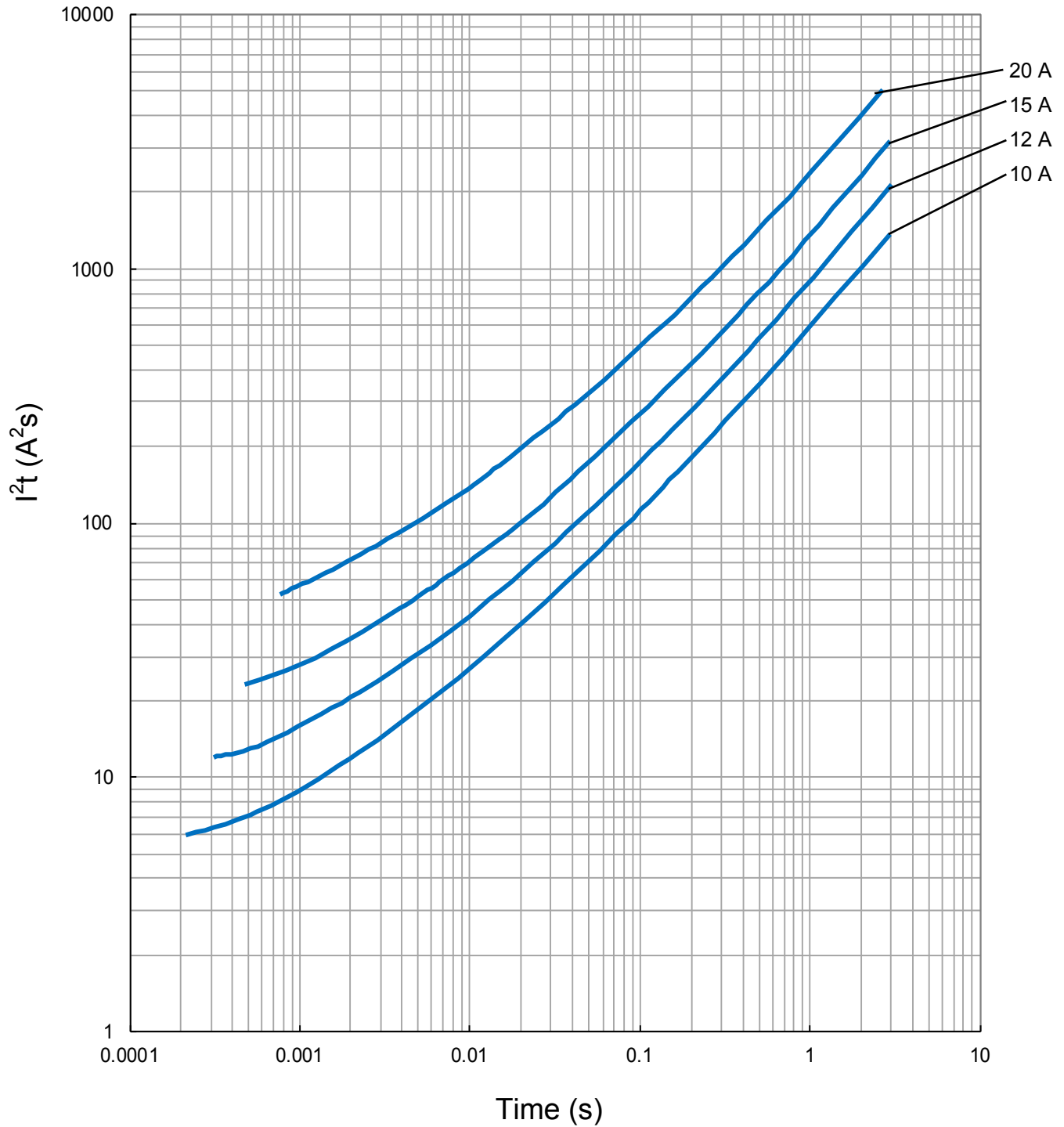

SolidMatrix® Surface Mount Fuses

HB Series (High Current), 1206 Size



Features:

- Special products for high current rating applications
- Higher current ratings and excellent inrush current withstanding capability (high I^2t)
- Glass ceramic monolithic structure
- Silver fusing element and silver termination with nickel and tin plating
- Superior arc suppression capability
- Symmetrical design with marking on both sides (optional)
- Operating temperature range: -55°C to 150°C (with de-rating)

Clearing Time Characteristics:

% of current rating	Clearing time at 25°C
100%	4 hours min.
350%	5 seconds max.

Shape and Dimensions:

Unit	Inch	mm
L	0.126 ± 0.008	3.20 ± 0.20
W	0.063 ± 0.008	1.60 ± 0.20
T	0.038 ± 0.008	0.97 ± 0.20
B	0.020 ± 0.010	0.51 ± 0.25

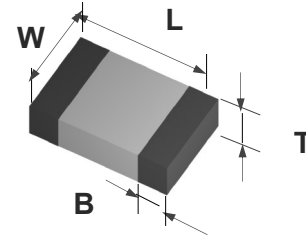

Agency Approval:

Recognized Under the Components Program of UL.
File Number: E232989.

Patents:

Patent numbers "US6,034,589", "US6,602,766", "US6,844,278", "ZL00134544.3", "ZL02114719.1", "ZL201020551360.8", "ZL201010299185.2", "ZL201220030614.0", "ZL201210020693.1".

Ordering Information:

Part Number	Current Rating (A)	Voltage Rating (VDC)	Interrupting Ratings	Nominal Cold DCR(Ω) ¹	Nominal I^2t (A^2s) ²	Marking Code ³
F1206HB10V024TM	10	24	150 A at rated voltage	0.0045	12	Q
F1206HB12V024TM	12	24		0.0039	19	X
F1206HB15V024TM	15	24	200 A at rated voltage	0.0031	34	Y
F1206HB20V024TM	20	24		0.0020	64	Z
F1206HB25V024TM	25	24	250 A at rated voltage	0.0016	187	S
F1206HB30V024TM	30	24	300 A at rated voltage	0.0012	270	V

1. Measured at $\leq 10\%$ rated current and 25°C ambient.
2. Melting I^2t at 1000% of current rating.
3. Red Marking Character Code.

SolidMatrix[®] Surface Mount Fuses HB Series (High Current), 1206 Size

Average Pre-arcing Time Curves:

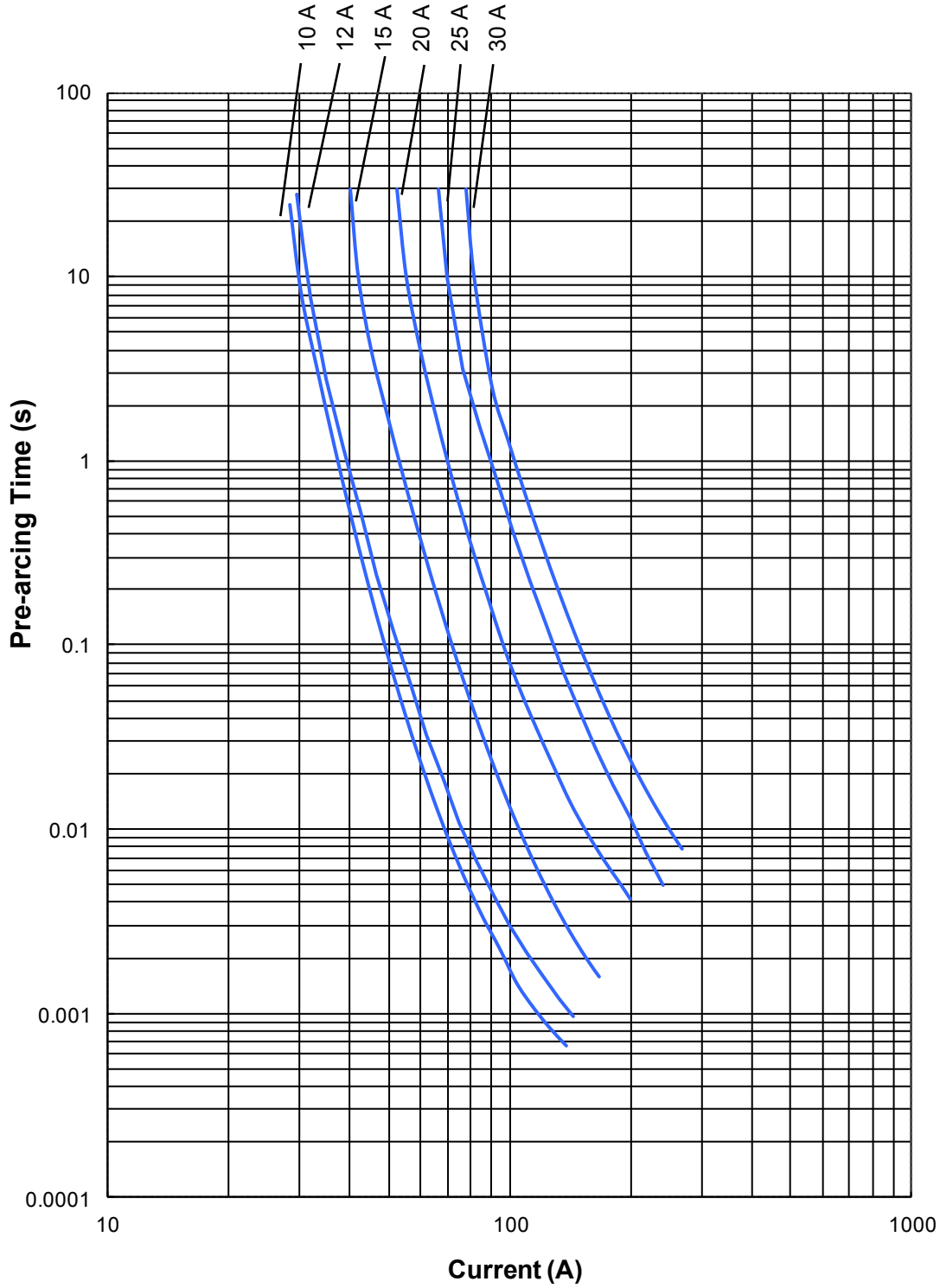

SolidMatrix[®] Surface Mount Fuses

HB Series (High Current), 1206 Size

Average I^2t vs. t Curves:

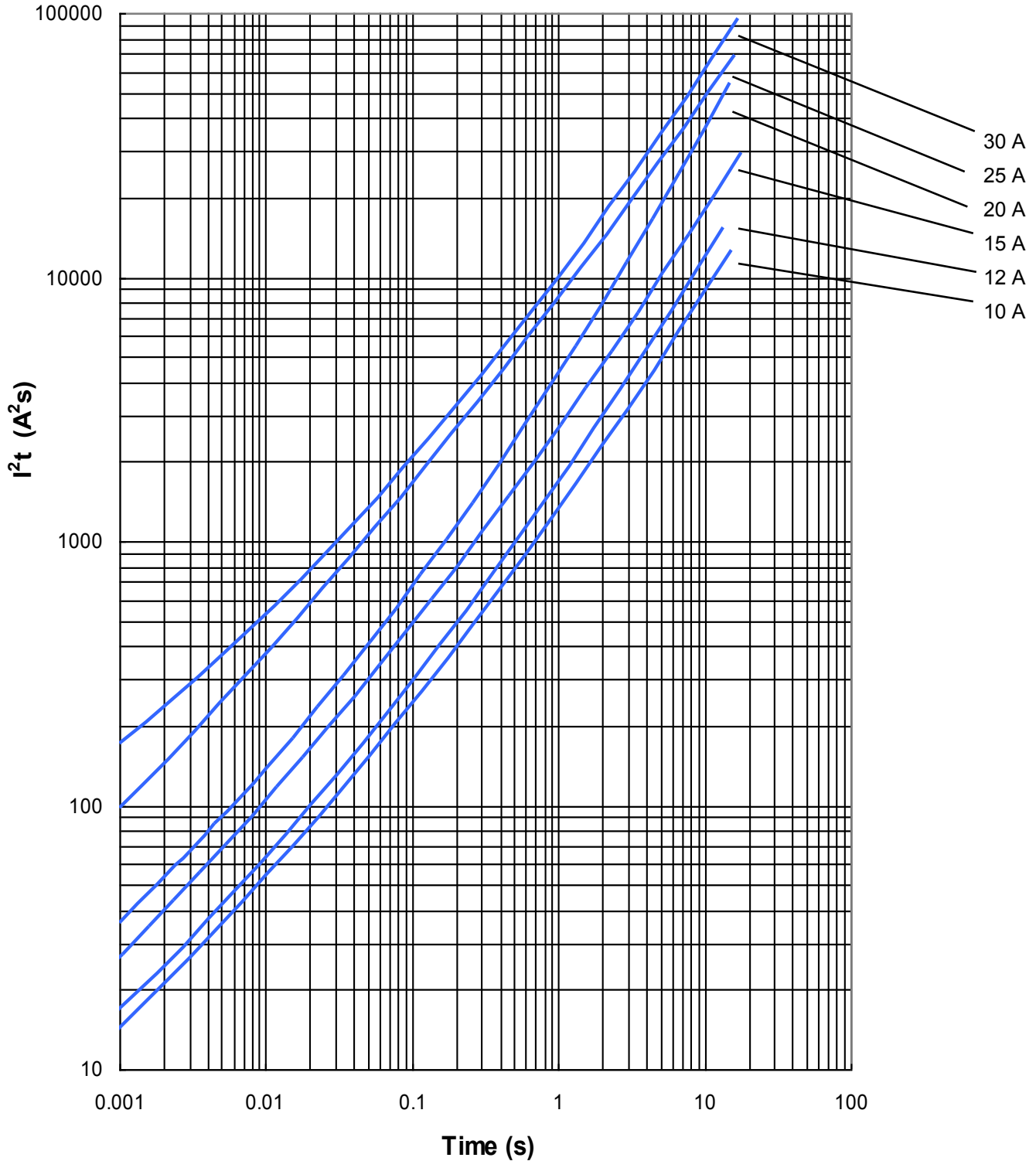

SolidMatrix[®] Surface Mount Fuses

HC Series (High Current), 1206 Size

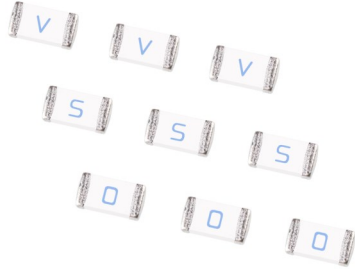

Features:

- High inrush current withstanding capability at high voltage
- Glass ceramic monolithic structure
- Silver fusing element and silver termination with nickel and tin plating
- Superior arc suppression capability
- RoHS compliant and lead free materials
- Operating temperature range: -55°C to +150°C (with de-rating)

Shape and Dimensions:

Unit	Inch	mm
L	0.126 ± 0.008	3.20 ± 0.20
W	0.063 ± 0.008	1.60 ± 0.20
T1	0.038 ± 0.008	0.97 ± 0.20
T2	0.051 ± 0.008	1.30 ± 0.20
B	0.020 ± 0.010	0.51 ± 0.25

T1: Thickness for 10-25A;
T2: Thickness for 30-40A.

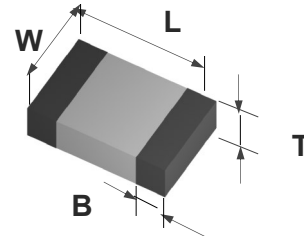

Clearing Time Characteristics:

% of current rating	Clearing time at 25°C
100%	4 hours min.
350%	5 seconds max.

Agency Approval:

Recognized Under the Components Program of UL.
File Number: E232989.

Patents:

Patent numbers "US6,034,589", "US6,602,766", "US6,844,278", "ZL00134544.3", "ZL02114719.1", "ZL201020551360.8", "ZL201010299185.2", "ZL201220030614.0", "ZL201210020693.1".

Ordering Information:

Part Number	Current Rating (A)	Voltage Rating (VDC)	Interrupting Ratings	Nominal Cold DCR(Ω) ¹	Nominal I ² t (A ² s) ²	Marking Code ³
F1206HC10A0TM	10	35	150A@35VDC	0.0055	15	Q
F1206HC12A0TM	12	35		0.0045	20	X
F1206HC15A0TM	15	35		0.0032	35	Y
F1206HC20A0TM	20	35		0.0023	80	Z
F1206HC25A0TM	25	35	200A@35VDC	0.0016	120	S
F1206HC30A0TM	30	35	200A@35VDC 300A@26VDC	0.0012	180	V
F1206HC40A0TM	40	35		0.0009	240	O

1. Measured at ≤ 10% rated current and 25°C ambient.

2. Melting I²t at 1000% of current rating.

3. Blue Marking Character Code. Devices designed to be mounted with marking code facing up.

SolidMatrix[®] Surface Mount Fuses HC Series (High Current), 1206 Size

Average Pre-arcing Time Curves:

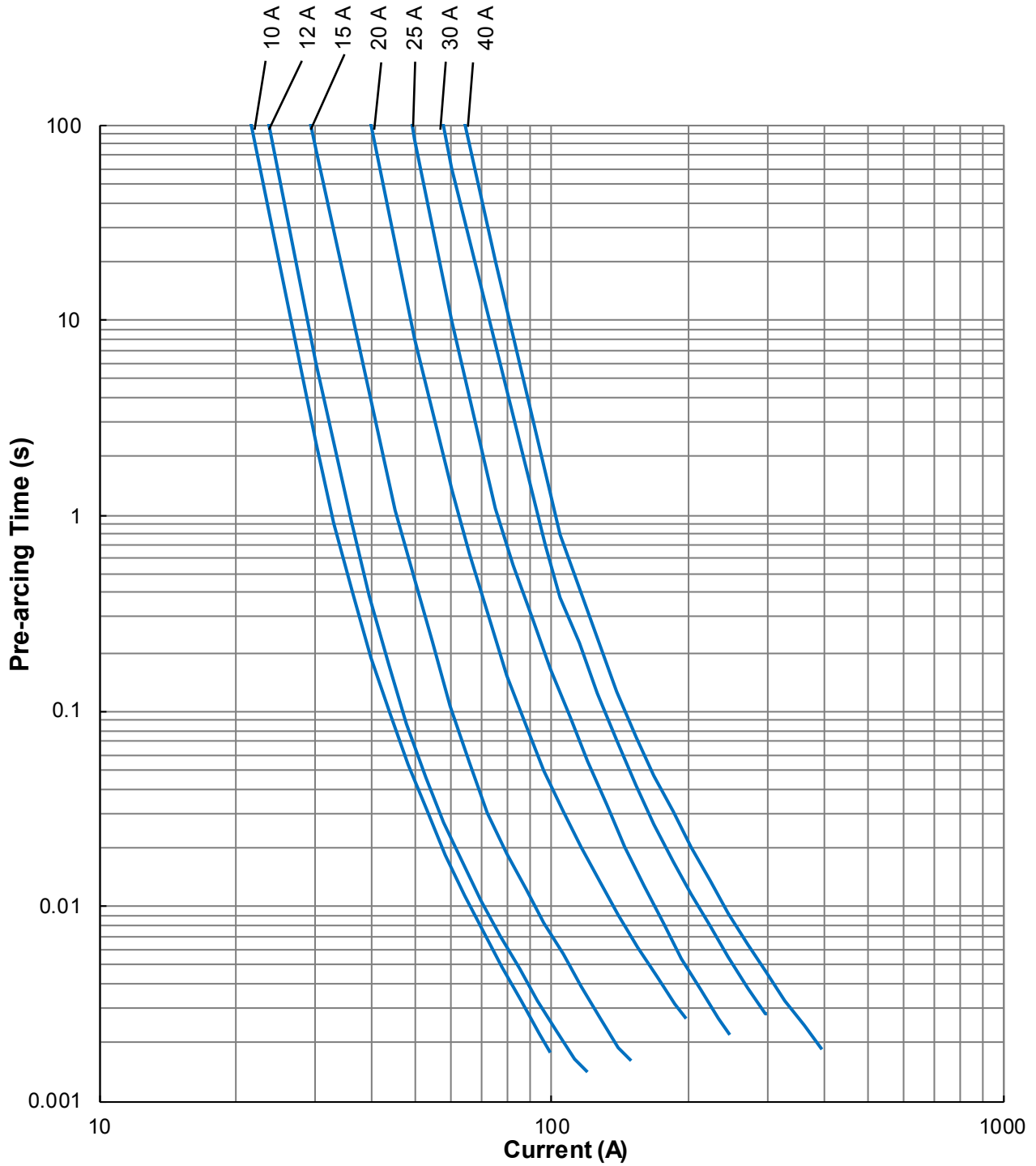

SolidMatrix[®] Surface Mount Fuses

HC Series (High Current), 1206 Size

Average I^2t vs. t Curves:

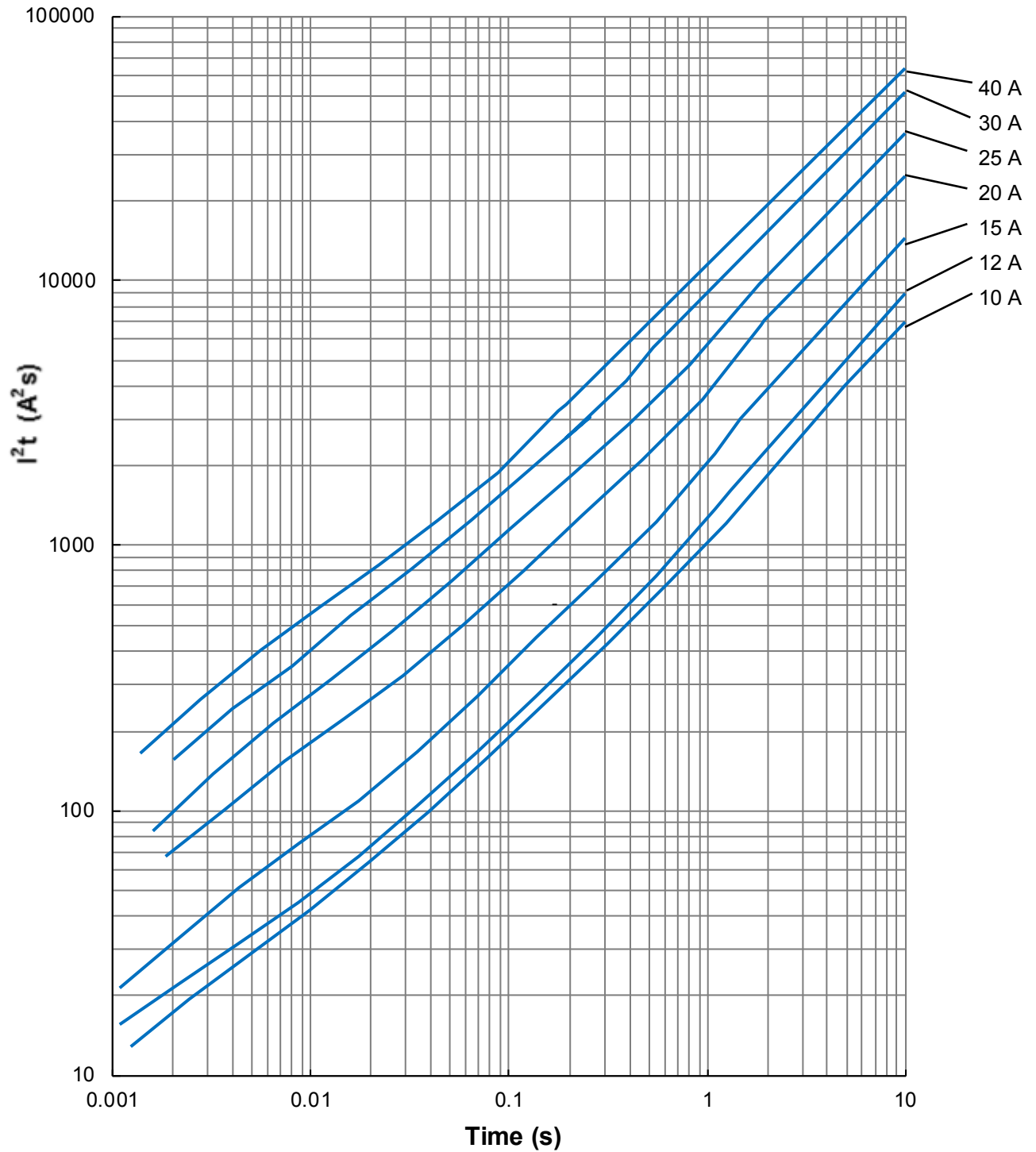

SolidMatrix® Surface Mount Fuses

FF Series (Very Fast Acting), 0603 Size



Features:

- Very fast acting at 200% and 300% overloads
- Excellent inrush current withstanding capability at high overloads
- Thin body for space limiting applications
- Glass ceramic monolithic structure
- Silver fusing element and silver termination with nickel and tin plating
- Symmetrical design with marking on both sides (optional)
- Operating temperature range: -55°C to +150°C (with de-rating)

Clearing Time Characteristics:

% of Current Rating	Clearing Time at 25°C	
	100%	4 hours min.
200%	0.01 seconds min.	5 seconds max.
300%	0.001 seconds min.	0.2 seconds max.

Agency Approval:

Recognized Under the Components Program of UL.
File Number: E232989.

Patents:

Patent numbers "US6,034,589", "US6,602,766",
"US6,844,278", "ZL00134544.3", "ZL02114719.1",
"ZL201020551360.8", "ZL201010299185.2",
"ZL201220030614.0", "ZL201210020693.1".

Shape and Dimensions:

Unit	Inch	mm
L	0.063 ± 0.006	1.60 ± 0.15
W	0.031 ± 0.006	0.80 ± 0.15
T	0.012 + 0.007 / -0.003	0.30 + 0.18 / -0.08
B	0.014 ± 0.006	0.36 ± 0.15

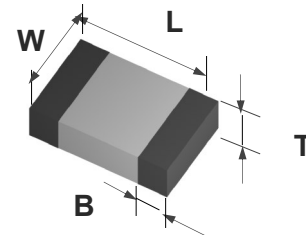

Ordering Information:

Part Number	Current Rating(A)	Voltage Rating (VDC)	Interrupting Ratings	Nominal Cold DCR(Ω) ¹	Nominal I ² t (A ² s) ²	Marking (Optional) ³
F0603FF0500V032T	0.5	32	50 A at rated voltage	1.000	0.0093	C
F0603FF0750V032T	0.75	32		0.450	0.0191	D
F0603FF1000V032T	1.0	32		0.280	0.036	E
F0603FF1250V032T	1.25	32	35 A at rated voltage	0.205	0.063	F
F0603FF1500V032T	1.5	32		0.143	0.095	G
F0603FF1750V032T	1.75	32		0.095	0.14	H
F0603FF2000V032T	2.0	32		0.073	0.21	I
F0603FF2500V032T	2.5	32		0.046	0.30	J
F0603FF3000V032T	3.0	32		0.039	0.46	K
F0603FF3500V032T	3.5	32		0.028	0.73	L
F0603FF4000V032T	4.0	32		0.023	1.15	M
F0603FF4500V032T	4.5	32		0.019	1.68	T
F0603FF5000V032T	5.0	32		0.015	2.62	N

1. Measured at ≤ 10% rated current and 25°C ambient.

2. Melting I²t at 0.001 second pre-arcing time.

3. Blue Marking Character Code.

SolidMatrix[®] Surface Mount Fuses

FF Series (Very Fast Acting), 0603 Size

Average Pre-arcing Time Curves:

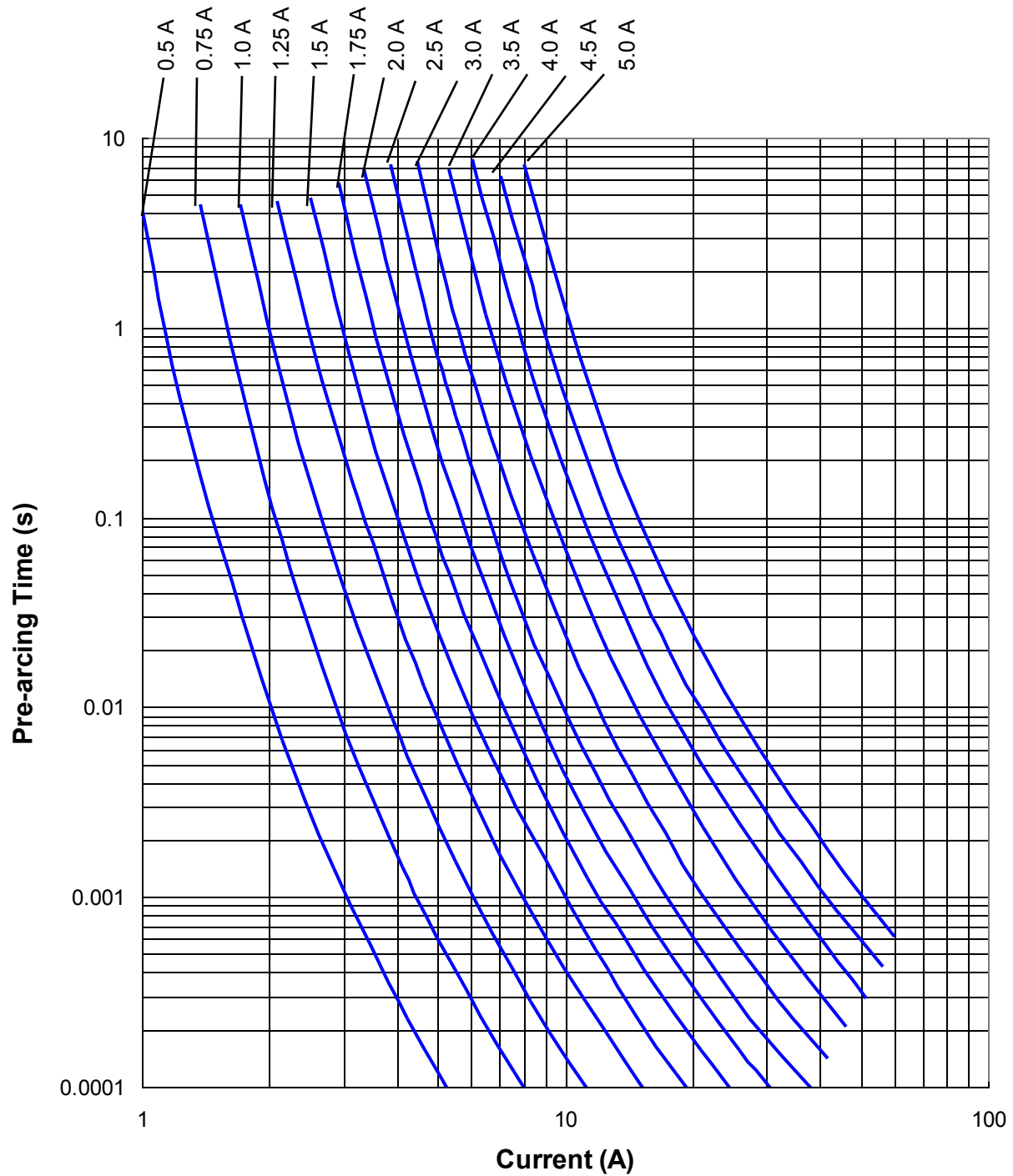

SolidMatrix[®] Surface Mount Fuses FF Series (Very Fast Acting), 0603 Size

Average I^2t vs. t Curves:

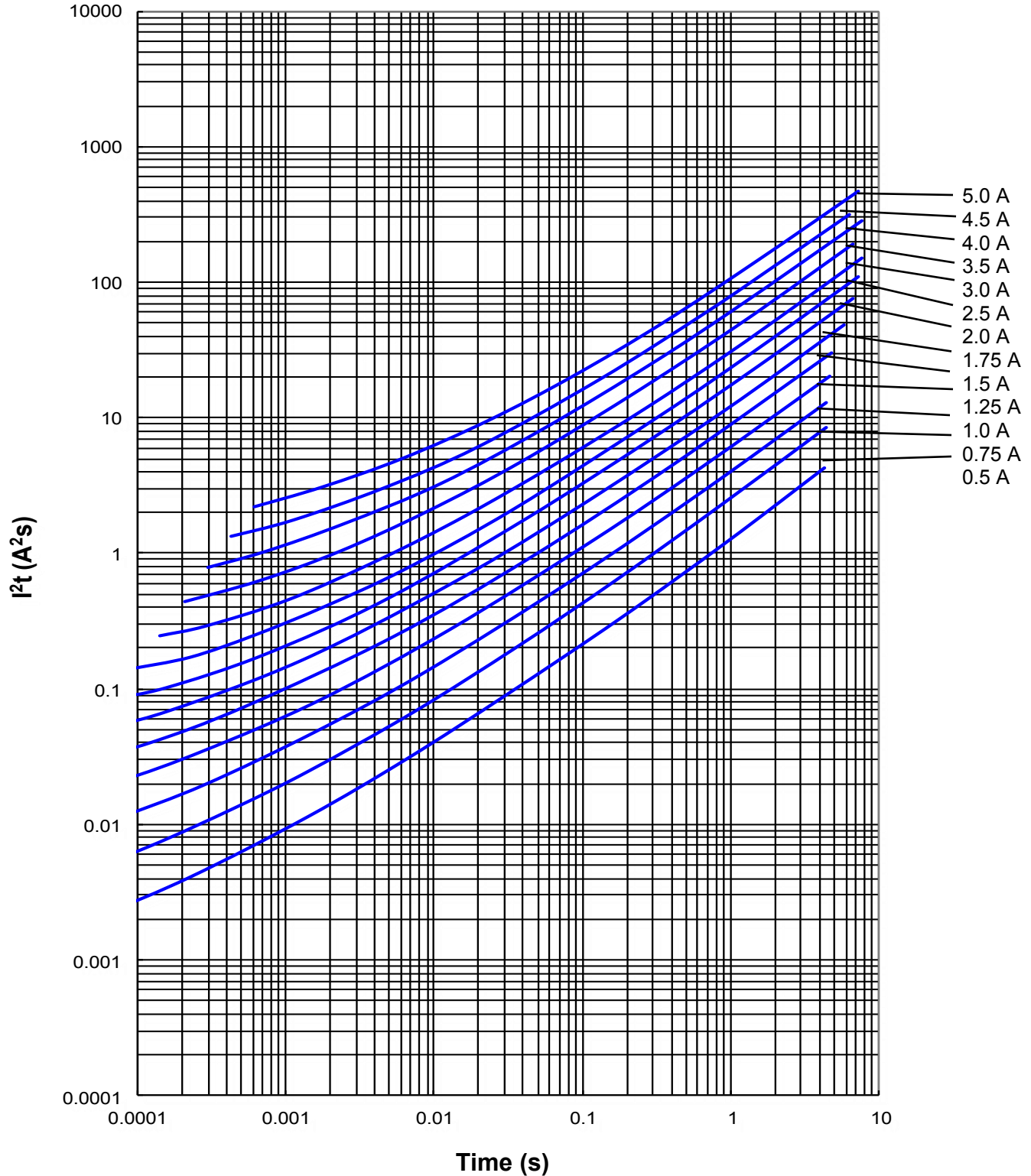

SolidMatrix[®] Surface Mount Fuses

VH Series (Voltage High), 1206 Size



Features:

- High inrush current withstanding capability
- Ceramic Monolithic structure
- Silver fusing element and silver termination with nickel and tin plating
- Symmetrical design with marking on both sides (optional)
- Operating temperature range: -55°C to +125°C (with de-rating)

Clearing Time Characteristics:

% of Current Rating	Clearing Time at 25°C	
	100%	4 hours min.
200% (2.5 A - 5.0 A)		60 seconds max.
350% (6.0 A - 8.0 A)		5 seconds max.
1000%	0.0002 seconds min.	0.02 seconds max.

Shape and Dimensions:

Unit	Inch	mm
L	0.126 ± 0.008	3.20 ± 0.20
W	0.063 ± 0.008	1.60 ± 0.20
T	0.034 ± 0.008	0.85 ± 0.20
B	0.020 ± 0.010	0.51 ± 0.25

Agency Approval:

Recognized Under the Components Program of UL.
File Number: E232989.

Patents:

Patent numbers "US6,034,589", "US6,602,766", "US7,268,661 B2", "ZL00134544.3", "ZL02114719.1", "ZL200410104280.7", "ZL201020551360.8", "ZL201010299185.2", "ZL201220030614.0", "ZL201210020693.1".

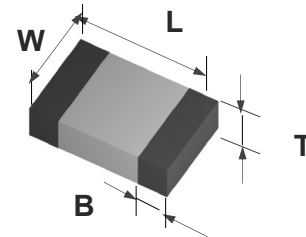

Ordering Information:

Part Number	Current Rating (A)	Voltage Rating (VDC)	Interrupting Ratings	Nominal Cold DCR(Ω) ¹	Nominal I ² t (A ² s) ²	Marking ³
F1206VH2500TM	2.5	65V	60A@ 65VDC 80A@48VDC 100A@32VDC	0.065	1.15	J
F1206VH3000TM	3.0			0.042	2.40	K
F1206VH3500TM	3.5			0.033	2.80	L
F1206VH4000TM	4.0			0.026	3.80	M
F1206VH4500TM	4.5			0.024	3.90	T
F1206VH5000TM	5.0			0.018	4.40	N
F1206VH6000TM	6.0	48V	80A@48VDC 100A@32VDC	0.011	13.0	+
F1206VH7000TM	7.0			0.009	19.0	-
F1206VH8000TM	8.0			0.007	20.0	=

1. Measured at ≤ 10% rated current and 25°C ambient.
2. Melting I²t at 10 times of rated current.
3. Blue Marking Character Code.

SolidMatrix[®] Surface Mount Fuses VH Series (Voltage High), 1206 Size

Average Pre-arcing Time Curves:

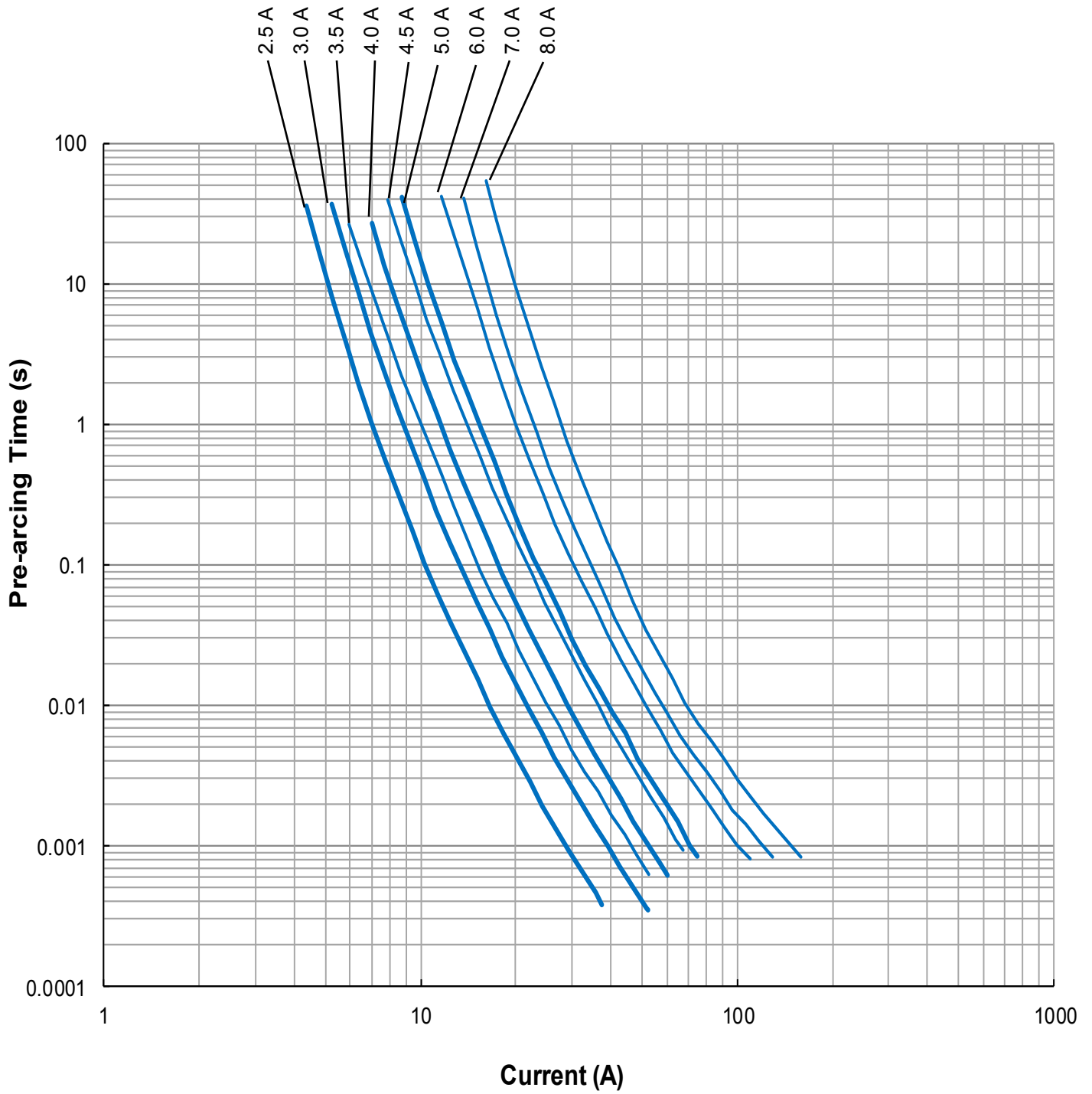

SolidMatrix[®] Surface Mount Fuses

VH Series (Voltage High), 1206 Size

Average I^2t vs. t Curves:

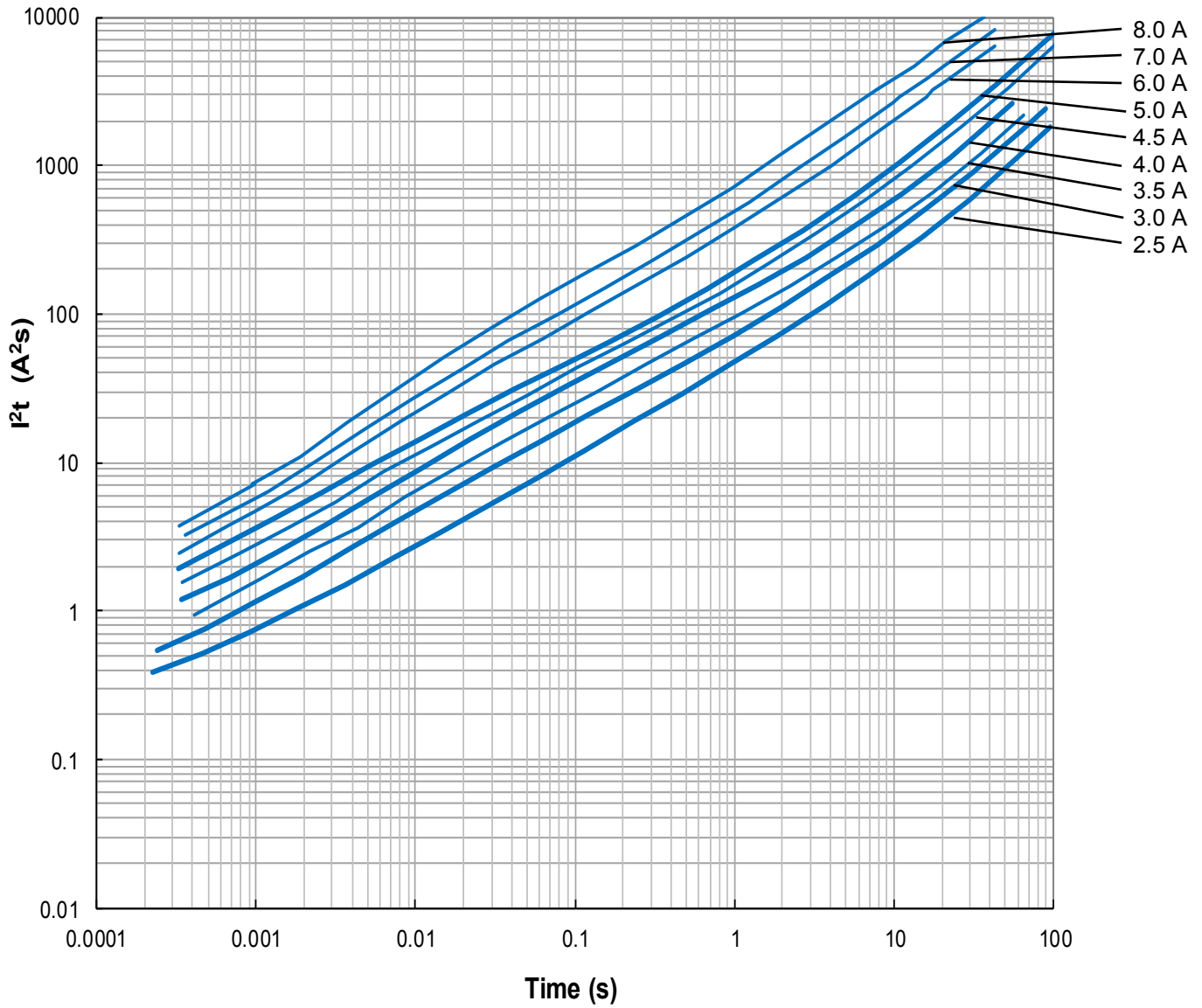

TF-FUSE® Thin Film Surface Mount Fuses

Product Identification:

T 0603 FF 1000 T M

(1) (2) (3) (4) (5) (6)

- (1) **Product Code:** T—Thin Film
- (2) **Size Code:** Standard EIA chip sizes
- (3) **Series Code:** FF—Very Fast Acting, HI—High Inrush
- (4) **Current Rating Code:** 0500—0.5A, 1000—1.0A
- (5) **Package Code:** T—Tape & Reel; B—Bulk

Environmental Tests:

No.	Test item	Requirement	Test condition	Reference
1	Bending	≤1A: 10% DCR change max. >1A: 20% DCR change max.	2mm	Refer to AEM QIQ034
2	Solderability	95% coverage min.	One dip at 255°C for 5 seconds	MIL-STD-202 Method 208
3	Thermal shock	DCR change within ±10% No mechanical damage	100 cycles between -55°C and +125°C	MIL-STD-202 Method 107
4	Moisture resistance	DCR change within ±10% No excessive corrosion	10 cycles	MIL-STD-202 Method 106
5	Salt spray	DCR change within ≤ ±10% No excessive corrosion	5% salt solution, 48 hour exposure	MIL-STD-202 Method 101
6	Mechanical vibration	DCR change within ≤ ±10% No mechanical damage	0.4" D.A. or 30G between 5 and 3000 Hz	MIL-STD-202 Method 204
7	Mechanical shock	DCR change within ≤ ±10% No mechanical damage	1500G, 0.5 ms, half sine shocks	MIL-STD-202 Method 213
8	Life	Change of voltage drop within ±10%, no open circuit	75% rated current, 2000 hours, ambient temperature +20°C to 30°C	Refer to AEM QIQ106

Packaging:

Chip Size	Parts on 7 inch (178mm) Reel
0603(1608)	8,000
0402(1005)	20,000

TF-FUSE® Thin Film Surface Mount Fuses

Temperature Effect on Current Rating:

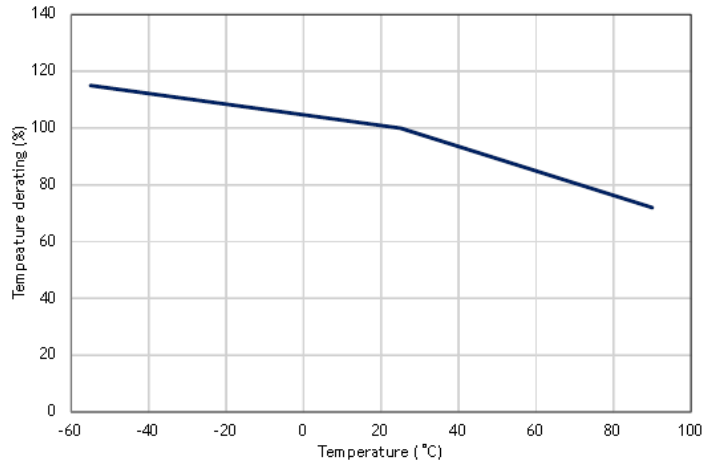

Recommended Reflow Soldering Profile:

Profile Feature	Pb-Free Assembly
Preheat/Soak	
Temperature Min (T_{smin})	150°C
Temperature Max (T_{smax})	200°C
Time (t_s) from (T_{smin} to T_{smax})	60~120 seconds
Ramp-up rate (T_L to T_p)	3°C/second max.
Liquidous temperature (T_L)	217°C
Time (t_L) maintained above T_L	60~150 seconds
Peak package body temperature (T_p)	260°C
Time (t_p)*within 5°C of the specified classification temperature (T_c)	30 seconds *
Ramp-down rate (T_p to T_L)	6°C/second max.
Time 25°C to peak temperature	8 minutes max.
* Tolerance for peak profile temperature (T_p) is defined as a supplier minimum and a user maximum	

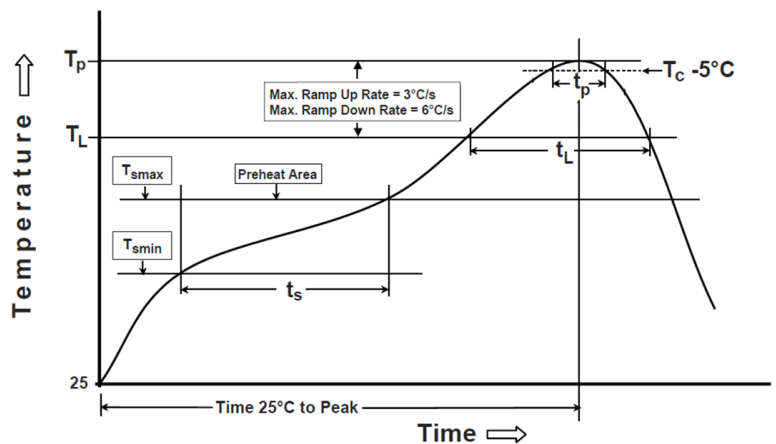

Thermal Shock When Making Correction with a Soldering Iron:

The temperature of soldering iron tip should be controlled under 350 °C and soldering time should be less than 3 sec. The soldering iron tip should not directly touch the top side termination of the component.

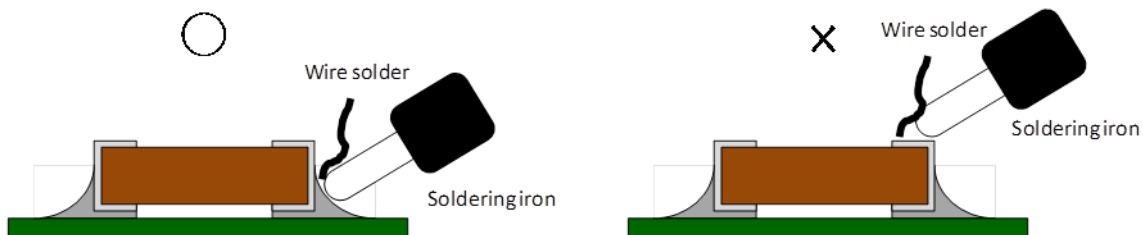
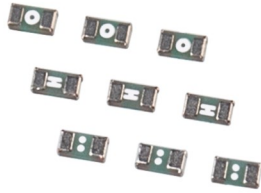

Fig 3 Correct handling method of soldering iron

TF-FUSE® Thin Film Surface Mount Fuses

FF Series (Very Fast Acting), 0402 Size



Features:

- Very fast acting
- Low DCR
- High inrush current withstanding capability
- Fiberglass enforced epoxy fuse body
- Copper termination with nickel and tin plating
- Halogen free, RoHS compliance and lead-free

Clearing Time Characteristics:

% of Current Rating	Ampere Rating	Opening Time at 25°C
100%	0.200A-5.00A	4 hours min.
200%	0.375A-5.00A	5 seconds max.
300%	0.200A-0.250A	5 seconds max.
	0.375A-5.00A	0.2 second max.

Shape and Dimensions:

Unit	Inch	mm
Length (L)	0.039± 0.004	1.00 ± 0.10
Width (W)	0.020 ± 0.004	0.51± 0.10
Thickness (T)	0.013 ± 0.004	0.33 ± 0.10
Termination bandwidth (b)	0.012 ± 0.004	0.30 ± 0.10

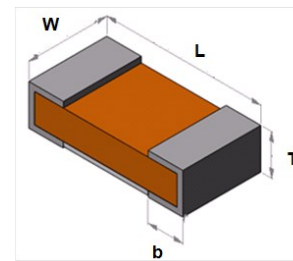

Agency Approval:

Recognized Under the Components Program of UL.
File Number: E232989.

Typical Ratings and Characteristics:

Operating temperature: -55 to +90°C

Part Number	Current Rating (A)	Voltage Rating (VDC)	Interrupting Rating	Nominal Cold DCR (Ω) ¹	Nominal I^2t (A ² s) ²	Marking
T0402FF0200TM	0.200	35	35A@35V DC	0.60	0.0017	..
T0402FF0250TM	0.250	35		:		
T0402FF0375TM	0.375	35		...		
T0402FF0500TM	0.50	35		I		
T0402FF0750TM	0.75	35		-		
T0402FF1000TM	1.00	35		+		
T0402FF1250TM	1.25	35		x		
T0402FF1500TM	1.50	35				
T0402FF1750TM	1.75	35		=		
T0402FF2000TM	2.00	35		≡		
T0402FF2500TM	2.50	35		H		
T0402FF3000TM	3.00	35		III		
T0402FF3500TM	3.50	35		III		
T0402FF4000TM	4.00	35		□		
T0402FF5000TM	5.00	35		○		

¹ Measured at $\leq 10\%$ of rated current and 25°C ambient .

² Melting I^2t at 0.001 second of current rating.

TF-FUSE® Thin Film Surface Mount Fuses

FF Series (Very Fast Acting), 0402 Size

Average Pre-arcing Time Curves:

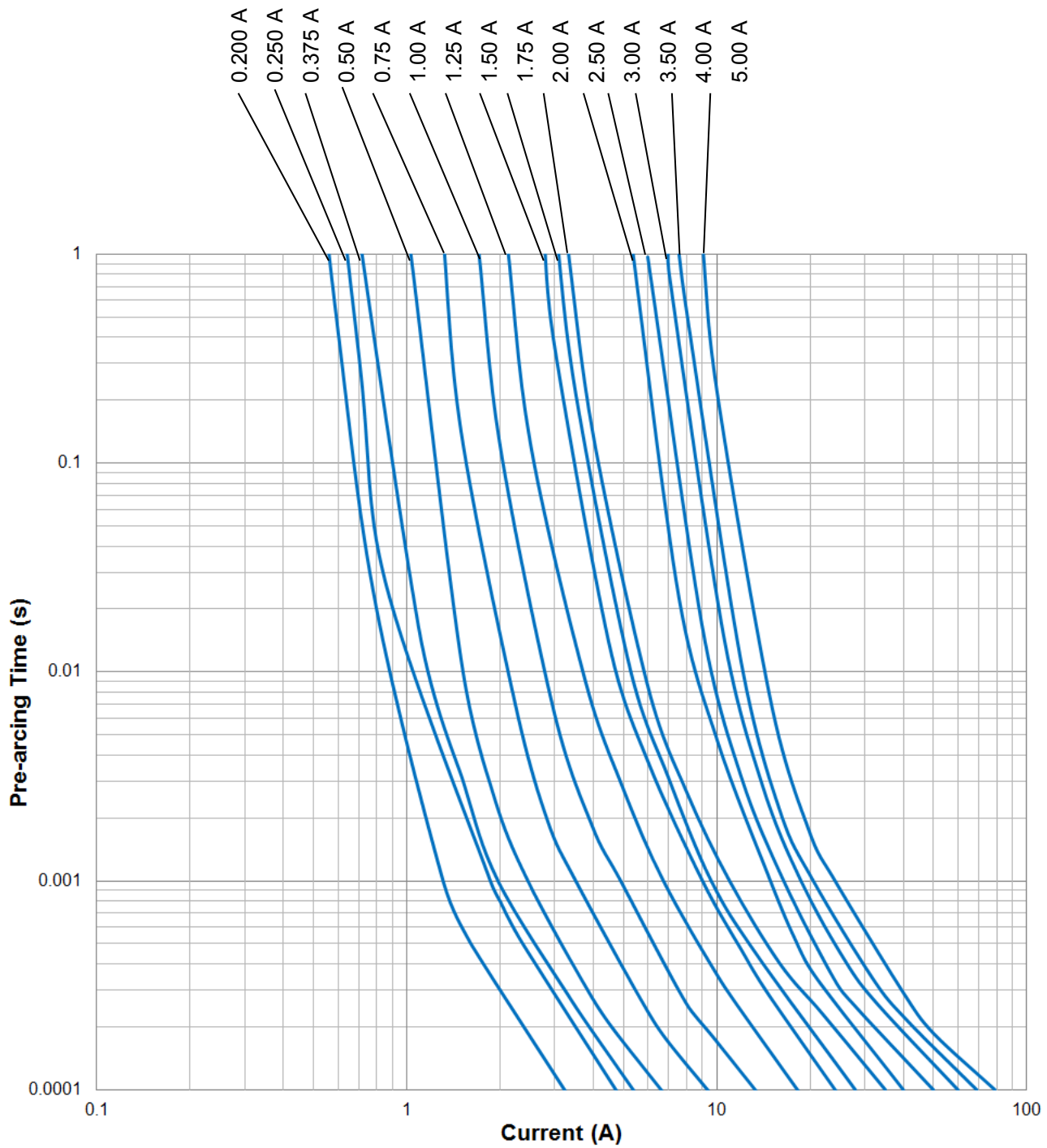

TF-FUSE[®] Thin Film Surface Mount Fuses

FF Series (Very Fast Acting), 0402 Size

Average I^2t vs. t Curves:

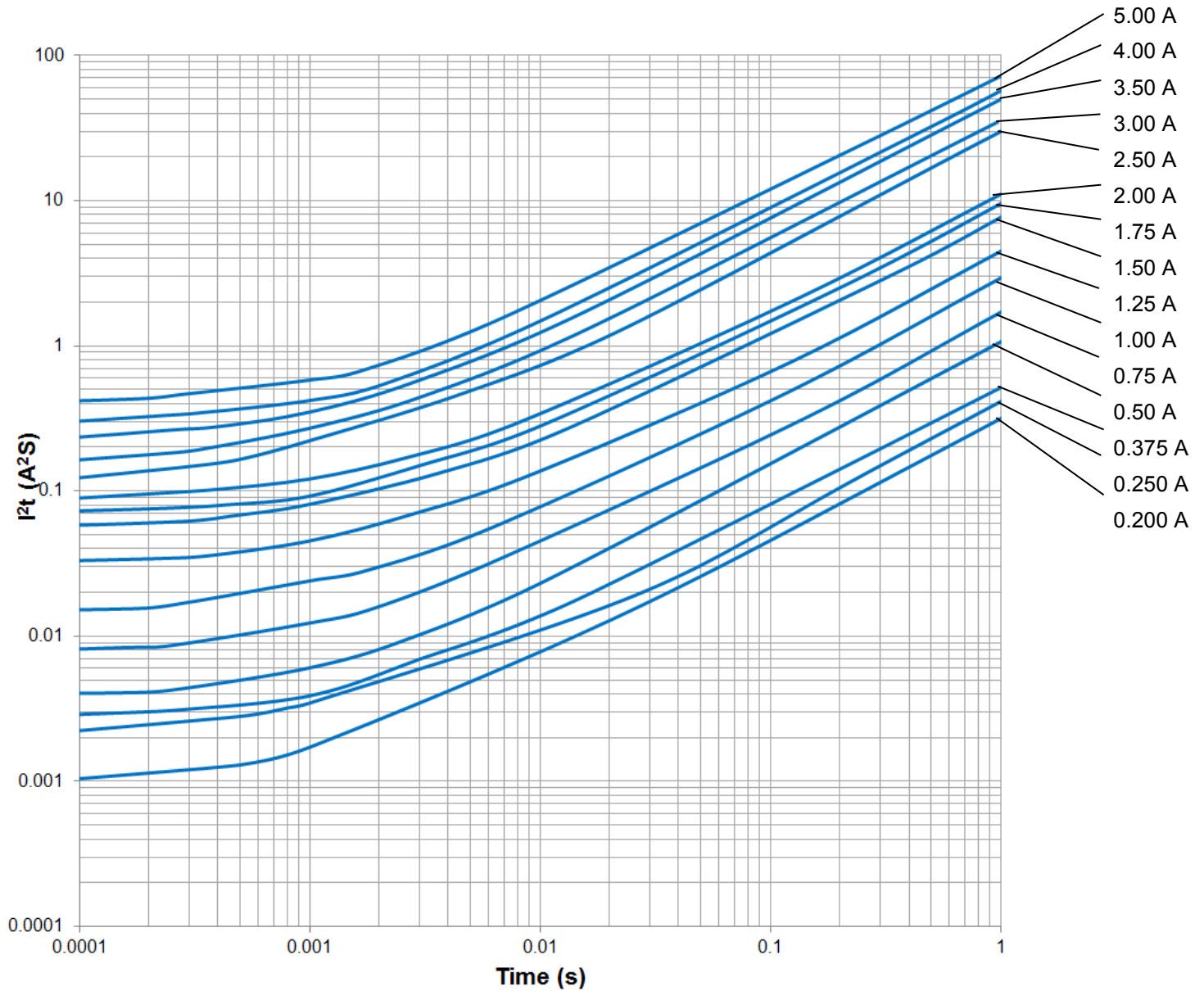

TF-FUSE® Thin Film Surface Mount Fuses

FF Series (Very Fast Acting), 0603 Size

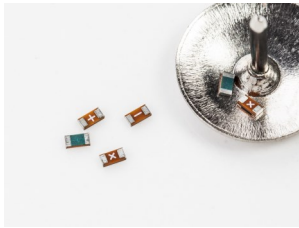

Features:

- Very fast acting at 200% overload current levels
- Low DCR
- High inrush current withstanding capability
- Fiberglass enforced epoxy fuse body
- Copper termination with nickel and tin plating
- Halogen free, RoHS compliance and lead-free

Applications:

- Notebook computers and tablets
- Digital cameras
- Memory cards
- Toys
- Bluetooth earphones
- Portable electronic devices

Shape and Dimensions:

Unit	Inch	mm
Length (L)	0.063 ± 0.004	1.60 ± 0.10
Width (W)	0.032 ± 0.004	0.81 ± 0.10
Thickness (T)	0.012 ± 0.004	0.30 ± 0.10
Termination bandwidth (b)	0.014 ± 0.004	0.36 ± 0.10

Clearing Time Characteristics:

% of Current Rating	Opening Time at 25°C
100%	4 hours min.
200%	5 seconds max.
300%	0.2 second max.

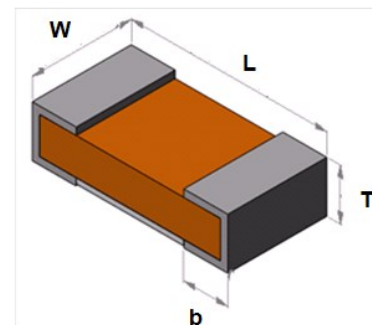

Agency Approval:

Recognized Under the Components Program of UL.
File Number: E232989.

Typical Ratings and Characteristics:

Operating temperature: -55 to +90°C

Part Number	Current Rating (A)	Voltage Rating (VDC)	Interrupting Rating	Nominal Cold DCR (Ω) ¹	Nominal I^2t (A ² s) ²	Marking
T0603FF0150TM	0.15	65	50A@35V DC/AC 13A@65V DC	2.2	0.0006	·
T0603FF0200TM	0.2	65		1.3	0.0014	..
T0603FF0250TM	0.25	65		1.1	0.0016	:
T0603FF0375TM	0.375	65		0.48	0.004	...
T0603FF0500TM	0.5	65		0.185	0.012	I
T0603FF0750TM	0.75	65		0.112	0.021	-
T0603FF1000TM	1	65		0.069	0.042	+
T0603FF1250TM	1.25	65	35A@35V DC/AC 13A@65V DC	0.048	0.052	×
T0603FF1500TM	1.5	65		0.037	0.071	
T0603FF1750TM	1.75	35	35A@35V DC/AC 50A@24V DC/AC	0.031	0.1	≡
T0603FF2000TM	2	35		0.026	0.14	=
T0603FF2500TM	2.5	35		0.021	0.24	H
T0603FF3000TM	3	35		0.0176	0.33	III
T0603FF3500TM	3.5	35		0.0148	0.49	HH
T0603FF4000TM	4	35		0.0125	0.63	□
T0603FF5000TM	5	35		0.0095	1.1	○

¹ Measured at ≤ 10% of rated current and 25°C ambient. ² Melting I^2t at 0.001 sec.

TF-FUSE® Thin Film Surface Mount Fuses

FF Series (Very Fast Acting), 0603 Size

Average Pre-arcing Time Curves:

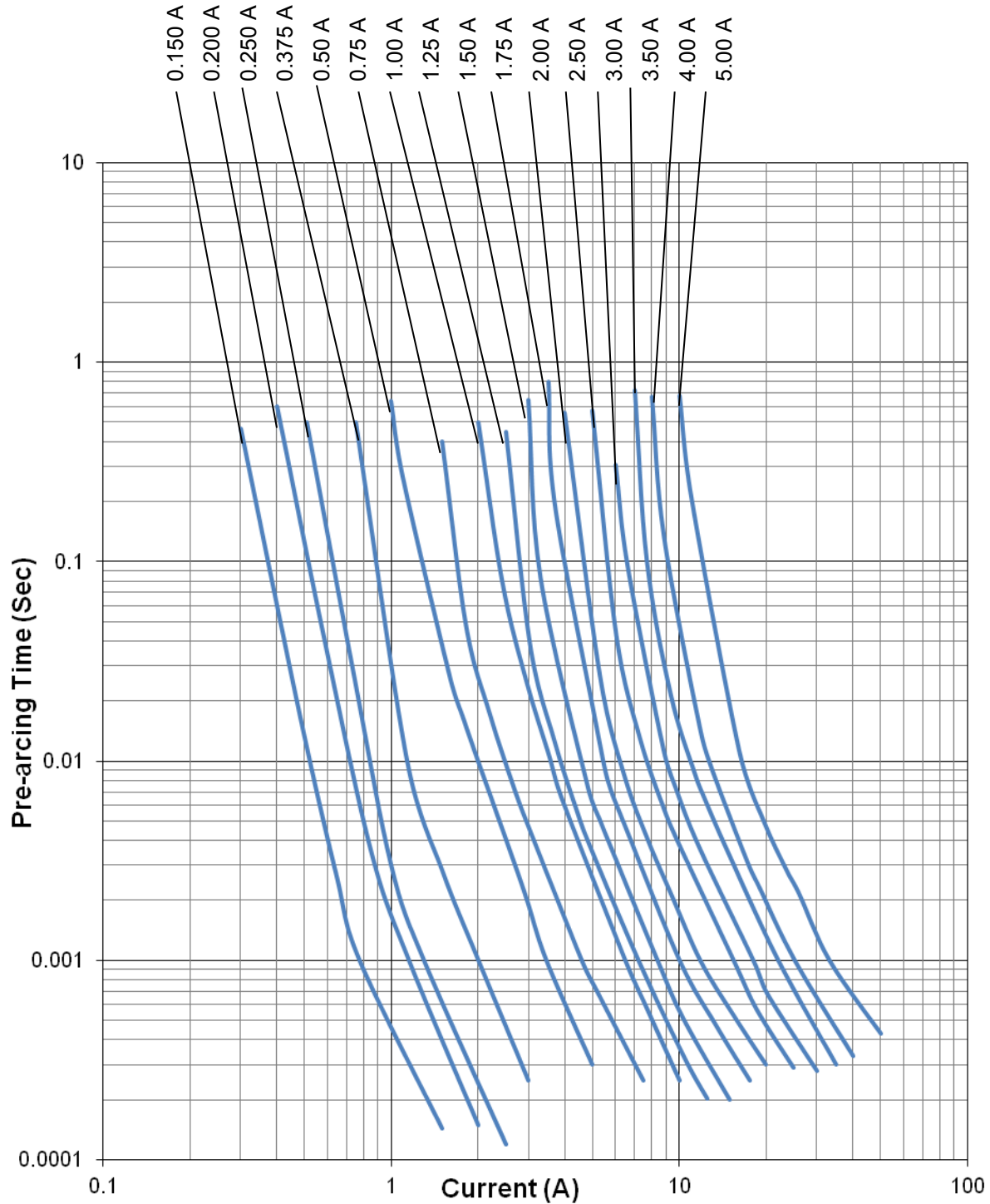

TF-FUSE® Thin Film Surface Mount Fuses

FF Series (Very Fast Acting), 0603 Size

Average I^2t vs. t Curves:

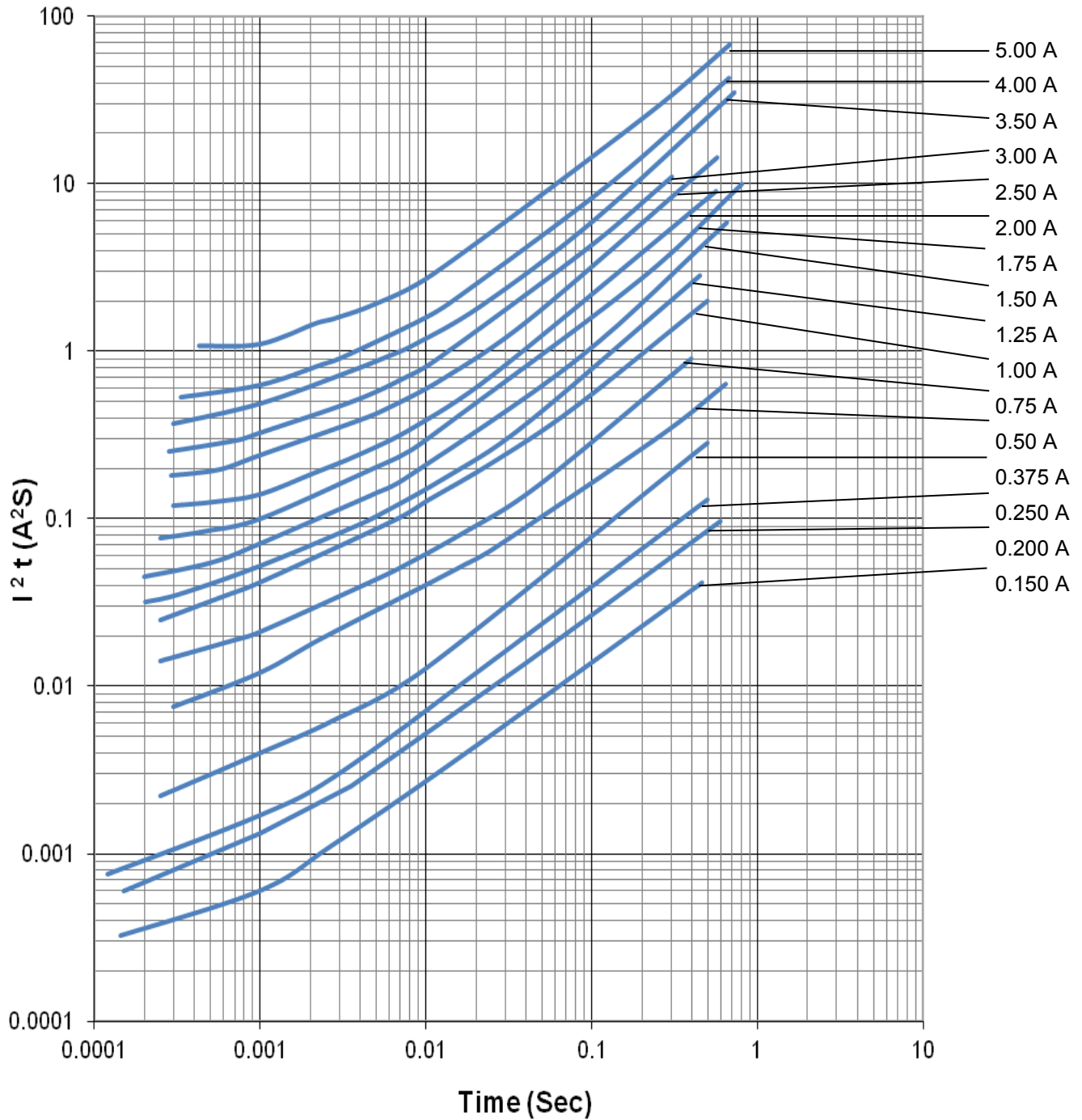

TF-FUSE® Thin Film Surface Mount Fuses

HI Series (High Inrush), 0603 Size



Features:

- Low DCR
- High inrush current withstanding capability
- Fiberglass enforced epoxy fuse body
- Copper termination with nickel and tin plating
- Halogen free, RoHS compliance and lead-free

Applications:

- Consumer Electronics
- Notebook Computers and Tablets
- Telecom Devices
- Mobile Phone
- Battery Pack
- Digital Camera

Shape and Dimensions:

Unit	Inch	mm
Length (L)	0.063 ± 0.004	1.60 ± 0.10
Width (W)	0.032 ± 0.004	0.81 ± 0.10
Thickness (T)	0.014 ± 0.004	0.36 ± 0.10
Termination bandwidth (b)	0.014 ± 0.004	0.36 ± 0.10

Clearing Time Characteristics:

% of Current Rating	Opening Time at 25°C	
	100%	4 hours min.
200%	1 second min.	60 seconds max.
1000%	0.0002 second min.	0.02 second max.

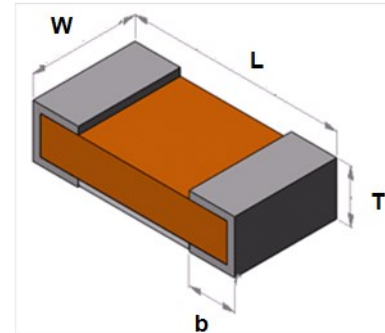

Agency Approval:

Recognized Under the Components Program of UL.
File Number: E232989.

Typical Ratings and Characteristics:

Operating temperature: -55 to +90°C

Part Number	Current Rating (A)	Voltage Rating (VDC)	Interrupting Rating	Nominal Cold DCR (Ω) ¹	Nominal I^2t (A^2s) ²	Marking
T0603HI0500TM	0.50	65	50A@35V DC/AC 13A@65V DC	0.1550	0.019	C
T0603HI0750TM	0.75	65		0.0830	0.036	D
T0603HI1000TM	1.00	65		0.0500	0.052	E
T0603HI1500TM	1.50	65		0.0290	0.110	T
T0603HI2000TM	2.00	35	35A@35V DC/AC 50A@24V DC/AC	0.0200	0.310	F
T0603HI2500TM	2.50	35		0.0165	0.400	J
T0603HI3000TM	3.00	35		0.0140	0.600	L
T0603HI3500TM	3.50	35		0.0120	0.800	N
T0603HI4000TM	4.00	35		0.0095	1.200	P

¹ Measured at $\leq 10\%$ of rated current and 25°C ambient.

² Melting I^2t at 0.001 sec.

TF-FUSE[®] Thin Film Surface Mount Fuses

HI Series (High Inrush), 0603 Size

Average Pre-arcing Time Curves:

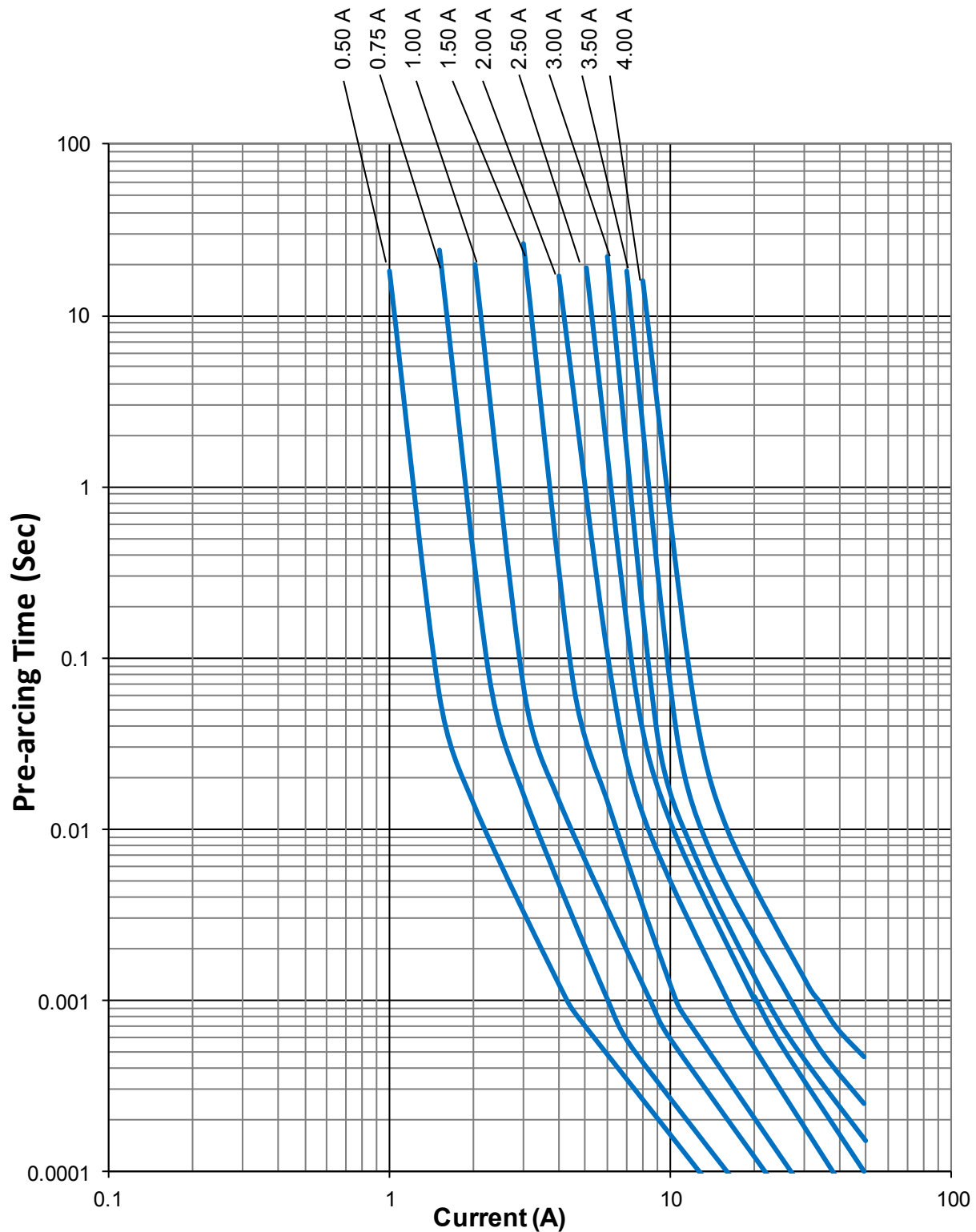

TF-FUSE® Thin Film Surface Mount Fuses
HI Series (High Inrush), 0603 Size

Average I^2t vs. t Curves:

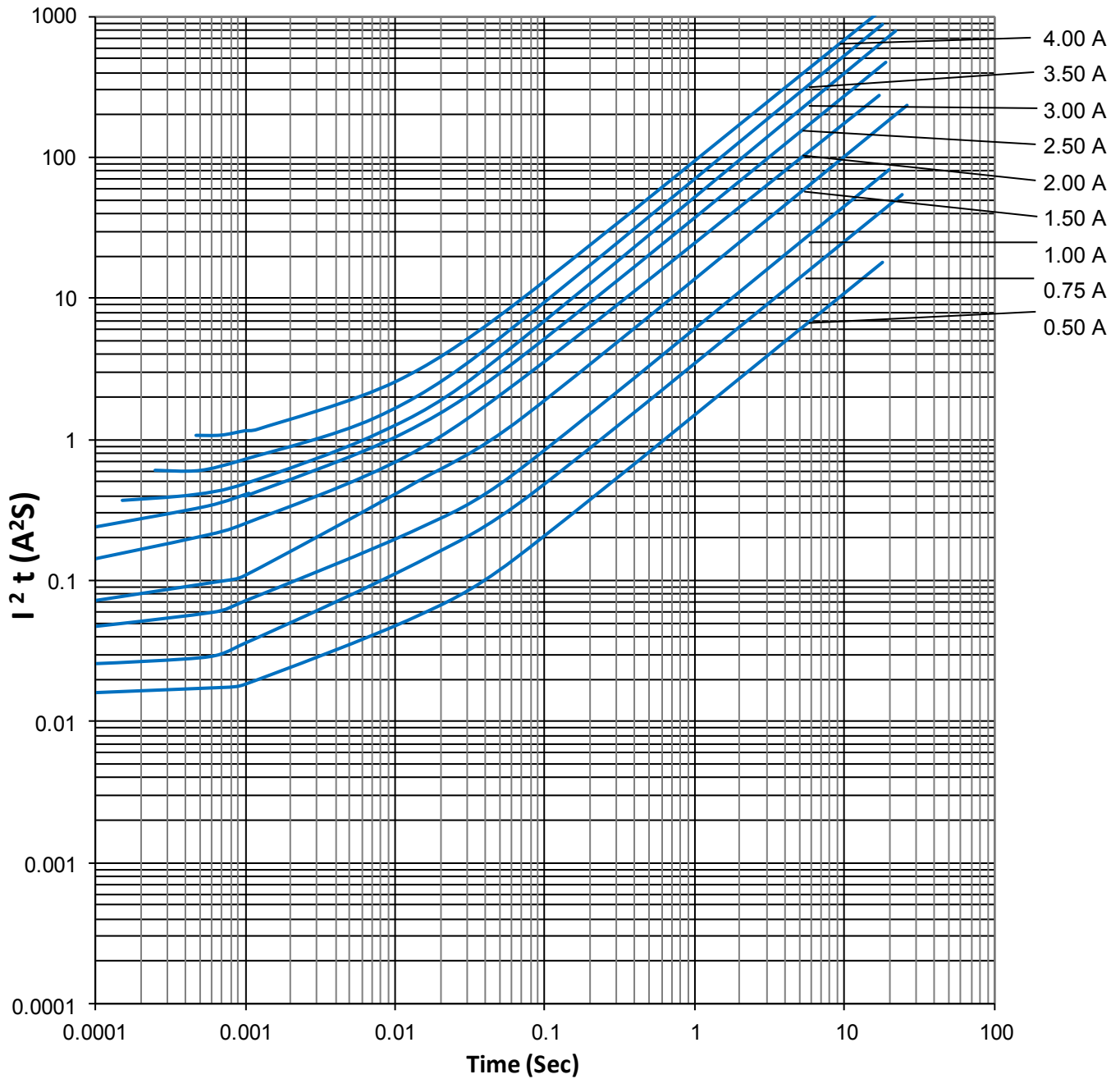

AirMatrix® Surface Mount Fuses

Product Identification:

AF2 1.00 V125 T M

(1) (2) (3) (4) (5)

- (1) **Series Code:** AF2
- (2) **Current Rating Code:** 1.00—1.00A
- (3) **Voltage Rating Code:** V125—125VDC
- (4) **Package Code:** T - Tape & Reel, B - Bulk
- (5) **Marking Code:** M - With Marking

AF 1206 F 2.00 T M

(1) (2) (3) (4) (5) (6)

- (1) **Series Code:** AF—AF Series, MF—MF Series
- (2) **Size Code:** Standard EIA Chip Sizes
- (3) **Time/Current Characteristic:** F
- (4) **Current Rating:** 2.00—2.00A
- (5) **Package Code:** T - Tape & Reel, B - Bulk
- (6) **Marking Code:** M - With Marking

Recommended Land Pattern:

	AF2		AF1206		MF2410		MF1210	
	Inch	mm	Inch	mm	Inch	mm	Inch	mm
L	0.338	8.60	0.173	4.40	0.338	8.60	0.170	4.40
G	0.118	3.00	0.059	1.50	0.118	3.00	0.070	1.70
H	0.124	3.15	0.071	1.80	0.110	2.80	0.110	2.70

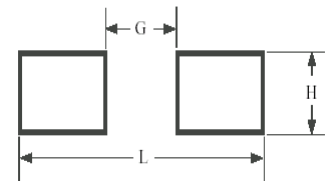

Packaging:

Chip Size	Parts on 7 inch (178 mm) Reel
2410 (6125)	2,000
1210 (3225)	2,500
1206 (3216)	3,500

Storage:

The maximum ambient temperature shall not exceed 35°C . Storage temperatures higher than 35°C could result in the deformation of packaging materials.

The maximum relative humidity recommended for storage is 75%. High humidity with high temperature can accelerate the oxidation of the solder plating on the termination and reduce the solderability of the components.

Sealed vacuum foil bags with desiccant should only be opened prior to use.

AirMatrix® Surface Mount Fuses

Fuse Selection and Temperature De-rating Guideline:

The ambient temperature affects the current carrying capacity of fuses. When a fuse is operating at a temperature higher than 25°C, the fuse shall be “de-rated”.

To select a fuse from the catalog, the following rule may be followed:

Catalog Fuse Current Rating = Nominal Operating Current / 0.75 / % De-rating at the maximum operating temperature.

Example: At maximum operating temperature of 65°C, % De-rating is 90%. The nominal operating current is 4 A. The current rating for fuse selected from the catalog shall be:

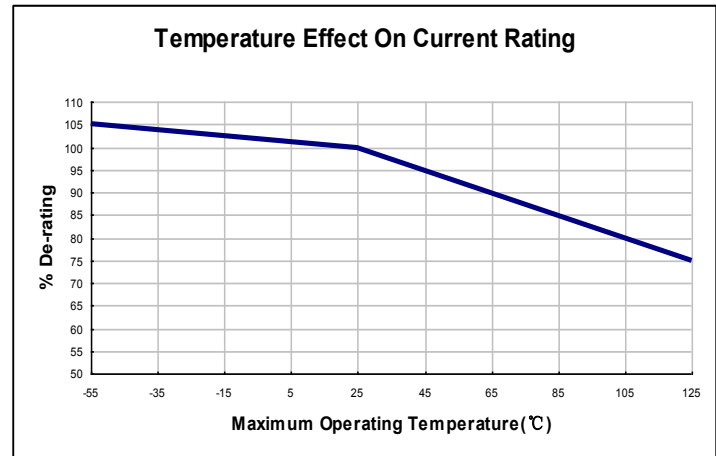

Environmental Tests:

Reliability Test	Test Condition and Requirement	Test Reference
Reflow & Bend	3 reflows at 245°C followed by a 2 mm bend, 20% DCR change max. (10% for ≤ 1 A), no mechanical damage	Refer to AEM QIQ034 ,QIQ048
Solderability	245°C, 5 seconds, new solder coverage 90% minimum	MIL-STD-202 Method 208
Soldering Heat Resistance	260°C, 10 seconds, 20% DCR change max. (10% for ≤ 1 A), new solder coverage 75% minimum	MIL-STD-202 Method 210
Life	25°C, 2000 hours, 80% rated current (75% for < 1 A), voltage drop change ≤ ±20%	Refer to AEM QIQ106
Thermal Shock	-65°C to +125°C, 100 cycles, 10% DCR change max., no mechanical damage	MIL-STD-202 Method 107
Mechanical Vibration	5 – 3000 Hz, 0.4 inch double amplitude or 30 G peak, 10% DCR change max., no mechanical damage	MIL-STD-202 Method 204
Mechanical Shock	1500 G, 0.5 milliseconds, half-sine shocks, 10% DCR change max., no mechanical damage	MIL-STD-202 Method 213
Salt Spray	5% salt solution, 48 hour exposure, 10% DCR change max., no excessive corrosion	MIL-STD-202 Method 101
Moisture Resistance	10 cycles, 15% DCR change max., no excessive corrosion	MIL-STD-202 Method 106

AirMatrix[®] Surface Mount Fuses

Soldering Temperature Profile:

* Recommended Temperature Profile for Reflow Soldering

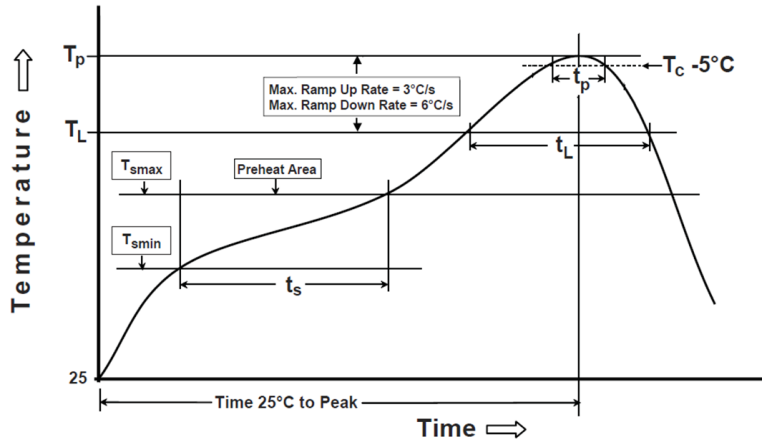

Profile Feature	Pb-Free Assembly
Preheat/Soak Temperature Min (T_{smin}) Temperature Max (T_{smax}) Time (t_s) from (T_{smin} to T_{smax})	150°C 200°C 60~120 seconds
Ramp-up rate (T_L to T_p)	3°C/second max.
Liquidous temperature (T_L) Time (t_L) maintained above T_L	217°C 60~150 seconds
Peak package body temperature (T_p)	260°C
Time (t_p)* within 5°C of the specified classification temperature (T_c)	30 seconds *
Ramp-down rate (T_p to T_L)	6°C/second max.
Time 25°C to peak temperature	8 minutes max.
* Tolerance for peak profile temperature (T_p) is defined as a supplier minimum and a user maximum	

* Recommended Temperature Profile for Wave Soldering

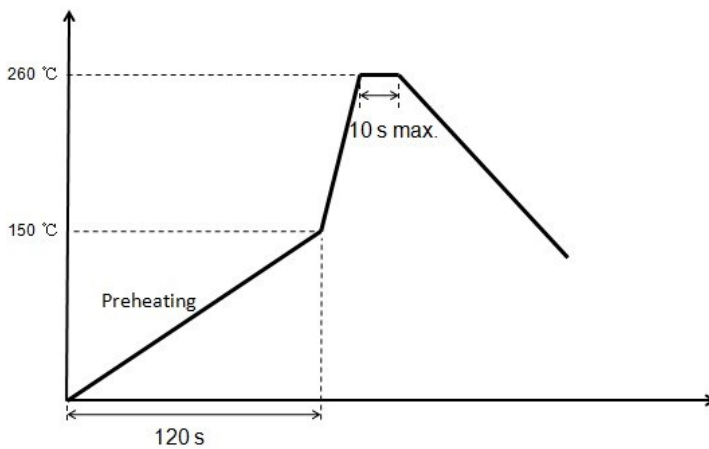

AirMatrix® Surface Mount Fuses

AF Series, 2410 Size



Features:

- Fast acting at 200% overload current level
- Excellent inrush current withstanding capability
- Fiberglass enforced epoxy fuse body
- Copper or copper alloy composite fuse link
- Copper termination with nickel and tin plating
- Halogen free, RoHS compliant and 100% lead-free
- Operating temperature range: -55°C to +125°C (with de-rating)

Application Fields:

- Power Supply, e.g. DC/DC converters, DC/AC inverters, Backlight drivers , etc.
- Consumer Electronics, e.g. LCD TVs, PDP, DVDs, PCM , etc.
- Communication Technology, e.g. Telecom systems, Networking, Modems, Routers, Changers, Base stations , etc.
- Office Automation Electronics
- IT Products, e.g. LCD monitors, Notebooks, PC servers, etc.

Shape and Dimensions:

Unit	Inch	mm
L	0.240 ± 0.006	6.10 ± 0.15
W	0.098 ± 0.006	2.49 ± 0.15
T	0.085 ± 0.008	2.16 ± 0.20
B	0.053 ± 0.015	1.35 ± 0.38

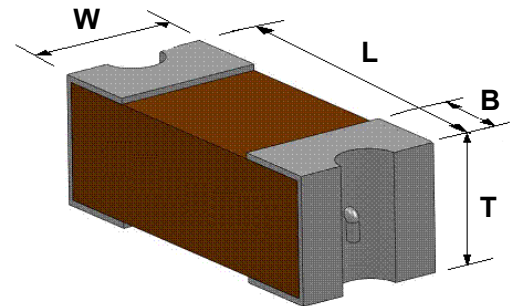

Clearing Time Characteristics:

% of Current Rating	Clearing Time at 25°C	
100%	4 hours min.	
200%(0.50~10.0 A)	0.01 seconds min.	5 seconds max.
200%(12.0~20.0 A)	0.01 seconds min.	20 seconds max.

Agency Approval:

- Recognized Under the Components Program of Underwriters Laboratories. File Number: E232989
- PSE Certificate No: NBK180711-JP13710
- TUV File Number: 50209083
- CQC No.: CQC11012065955

Patents:

Patent numbers "ZL200810092353.3", "ZL200910007157.6", "ZL201120450579.3", "ZL201120536307.5", "ZL201220063222.4", "ZL201110123326.X".

AirMatrix® Surface Mount Fuses

AF Series, 2410 Size

Ordering Information:

Part Number	Current Rating (A)	Voltage Rating (V)		Interrupting Rating	Nominal Cold DCR (Ω) ¹	Nominal I^2t (A^2s) ²	Agency Approval				Marking (Optional) ³
		AC	DC				UL	PSE	TUV	CQC	
AF2-0.50V125TM	0.5	250		TUV: 0.5 ~ 2 A 100 A @ 250 VAC 50 A @ 125 VDC	0.231	0.10	✓		✓	✓	C
AF2-0.63V125TM	0.63				0.174	0.16	✓		✓		S
AF2-0.75V125TM	0.75				0.148	0.23	✓				D
AF2-1.00V125TM	1.0				0.093	0.59	✓	✓	✓	✓	E
AF2-1.25V125TM	1.25				0.07	0.96	✓	✓	✓		F
AF2-1.50V125TM	1.5				0.062	1.19	✓	✓			G
AF2-2.00V125TM	2.0				0.042	2.75	✓	✓	✓	✓	I
AF2-2.50V125TM	2.5				0.031	1.21	✓	✓			J
AF2-3.00V125TM	3.0				0.0249	1.73	✓	✓			K
AF2-3.15V125TM	3.15				0.0232	2.2	✓	✓			V
AF2-3.50V125TM	3.5	125		CQC: 0.5 A, 1 A, 2 A 100 A @ 250 VAC 50 A @ 125 VDC	0.022	2.5	✓	✓			L
AF2-4.00V125TM	4.0				0.0172	4.1	✓	✓			M
AF2-5.00V125TM	5.0				0.0143	5.9	✓	✓			N
AF2-6.30V125TM	6.3				0.01	12.5	✓				O
AF2-7.00V125TM	7.0				0.0094	14.2	✓				P
AF2-8.00V125TM	8.0				0.0086	20.3	✓				R
AF2-10.0V125TM	10.0				0.0066	29.2	✓				Q
AF2-12.0V065TM	12.0	65	65	PSE: 1 ~ 5 A 50 A @ 125 VAC	0.0053	49.2	✓				X
AF2-15.0V065TM	15.0				0.0038	102.5	✓				Y
AF2-20.0V065TM	20.0				0.0034	126.2	✓				Z

1. Measured at $\leq 10\%$ rated current and 25°C ambient.
 2. Melting I^2t at 0.001 second pre-arcing time.
 3. White Marking Character Code.

AirMatrix[®] Surface Mount Fuses

AF Series, 2410 Size

Average Pre-arcing Time Curves:

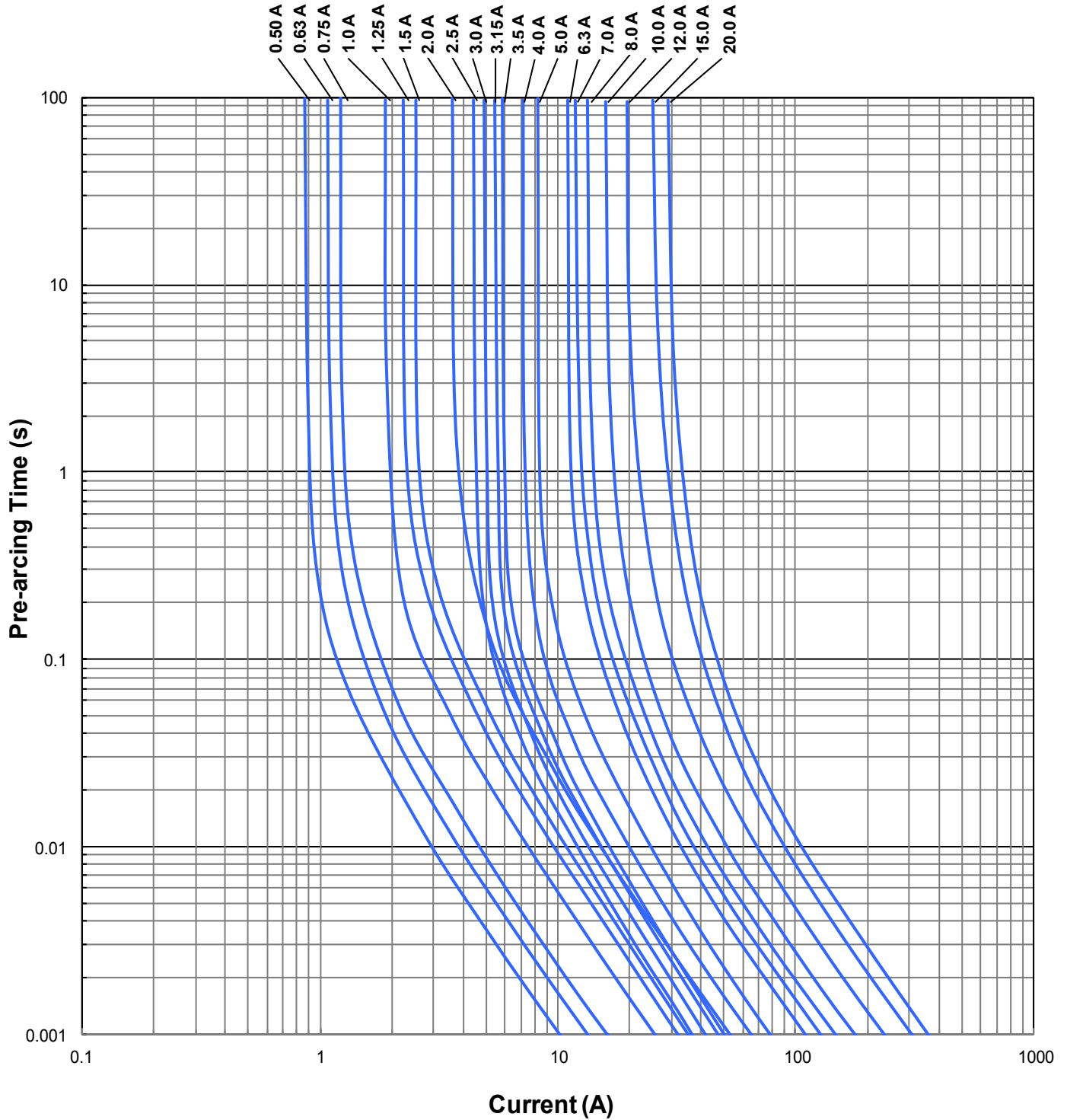

AirMatrix[®] Surface Mount Fuses

AF Series, 2410 Size

Average I^2t vs. t Curves:

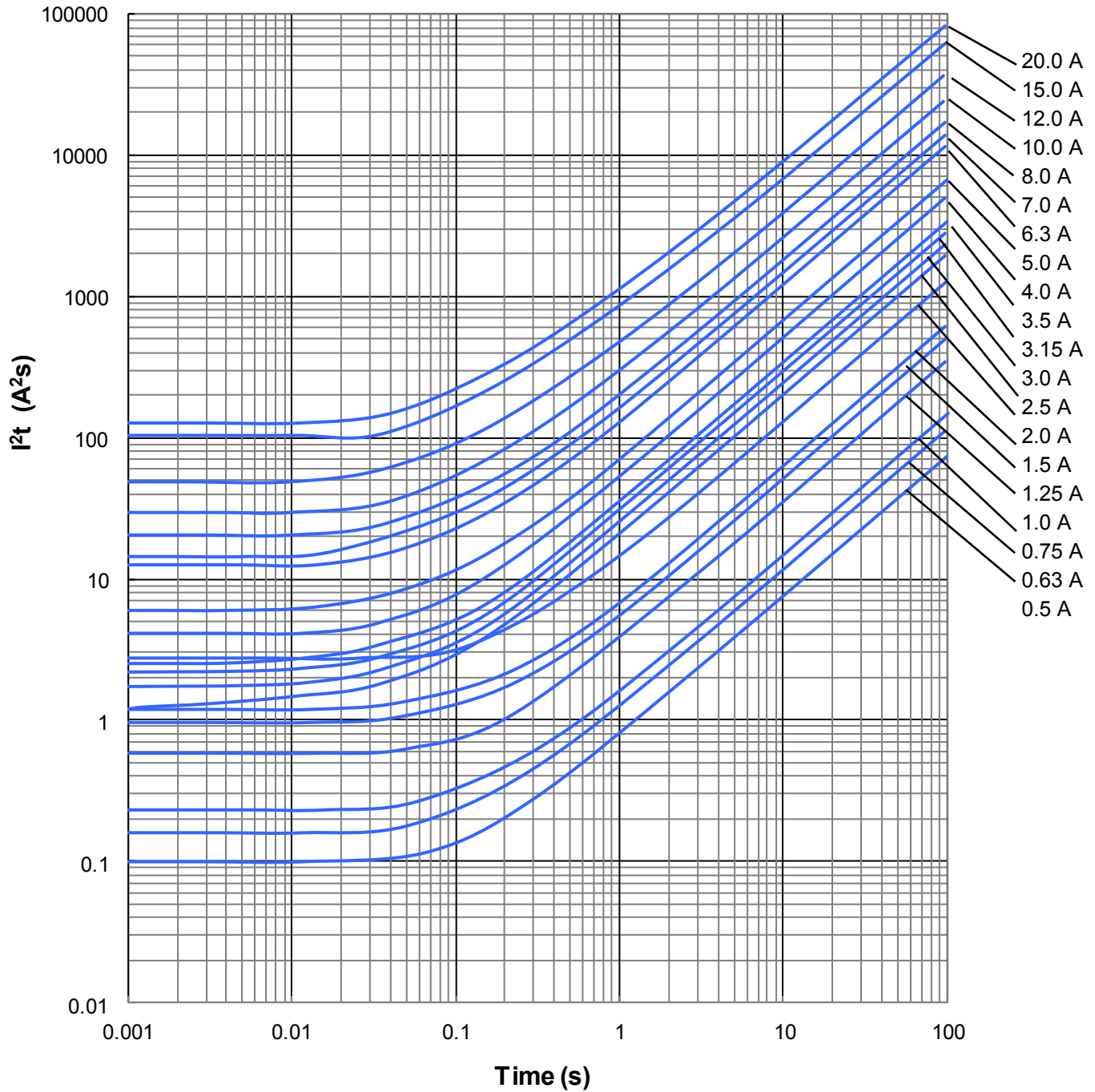

AirMatrix[®] Surface Mount Fuses

AF Series, 1206 Size



Features:

- Fast acting at 250% overload current level
- Excellent inrush current withstanding capability
- Extremely thin body for space saving
- Much safer with wire-in-air design
- Fiberglass enforced epoxy fuse body
- Copper termination with nickel and tin plating
- Operating temperature range: -55°C to +125 °C (with de-rating)
- 100% lead-free

Application Fields:

- Notebook, Ultrabook
- Backlight Driver
- DC/DC Converter
- Low voltage lighting power
- Automotive electronics

Shape and Dimensions:

Unit	Inch	mm
L	0.126 ± 0.008	3.20 ± 0.20
W	0.063 + 0.012 / -0.004	1.60 + 0.30 / -0.20
T	0.042 ± 0.006	1.08 ± 0.15
B	0.033 ± 0.012	0.85 ± 0.30

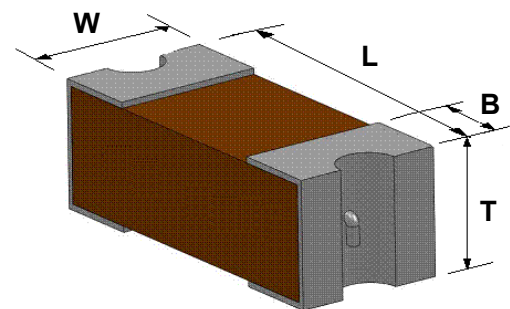

Clearing Time Characteristics:

% of Current Rating	Clearing Time at 25°C	
	Min.	Max.
100%	4 hour	
250%		5 seconds

Agency Approval:

Recognized Under the Components Program of Underwriters Laboratories. File Number: E232989

AirMatrix® Surface Mount Fuses

AF Series, 1206 Size

Ordering Information:

Part Number	Current Rating (A)	Marking (White)	Voltage Rating (VDC)	Interrupting Rating	Nominal DCR (Ω)	Nominal I ² t (A ² s)
AF1206F1.50TM	1.50	G	65	50A@65VDC	0.050	0.37
AF1206F1.60TM	1.60	T			0.043	0.52
AF1206F2.00TM	2.00	I			0.032	0.88
AF1206F2.50TM	2.50	J			0.028	1.1
AF1206F3.00TM	3.00	K			0.022	1.9
AF1206F3.15TM	3.15	V			0.020	2.2
AF1206F3.50TM	3.50	L			0.018	2.6
AF1206F4.00TM	4.00	M			0.016	3.3
AF1206F5.00TM	5.00	N	32	50A@32VDC	0.013	5.4
AF1206F6.30TM	6.30	O			0.010	8.9
AF1206F7.00TM	7.00	P			0.0092	10.4
AF1206F8.00TM	8.00	R			0.0084	13.5
AF1206F10.0TM	10.0	Q			0.0050	11.2
AF1206F12.0TM	12.0	X			0.0041	15.0
AF1206F15.0TM	15.0	Y			0.0035	24.5

1. Resistance is measured at $\leq 10\%$ of rated current and 25°C ambient.
2. Melting I²t is calculated at 0.001 second pre-arcing time.

AirMatrix[®] Surface Mount Fuses

AF Series, 1206 Size

Average Pre-arcing Time Curves:

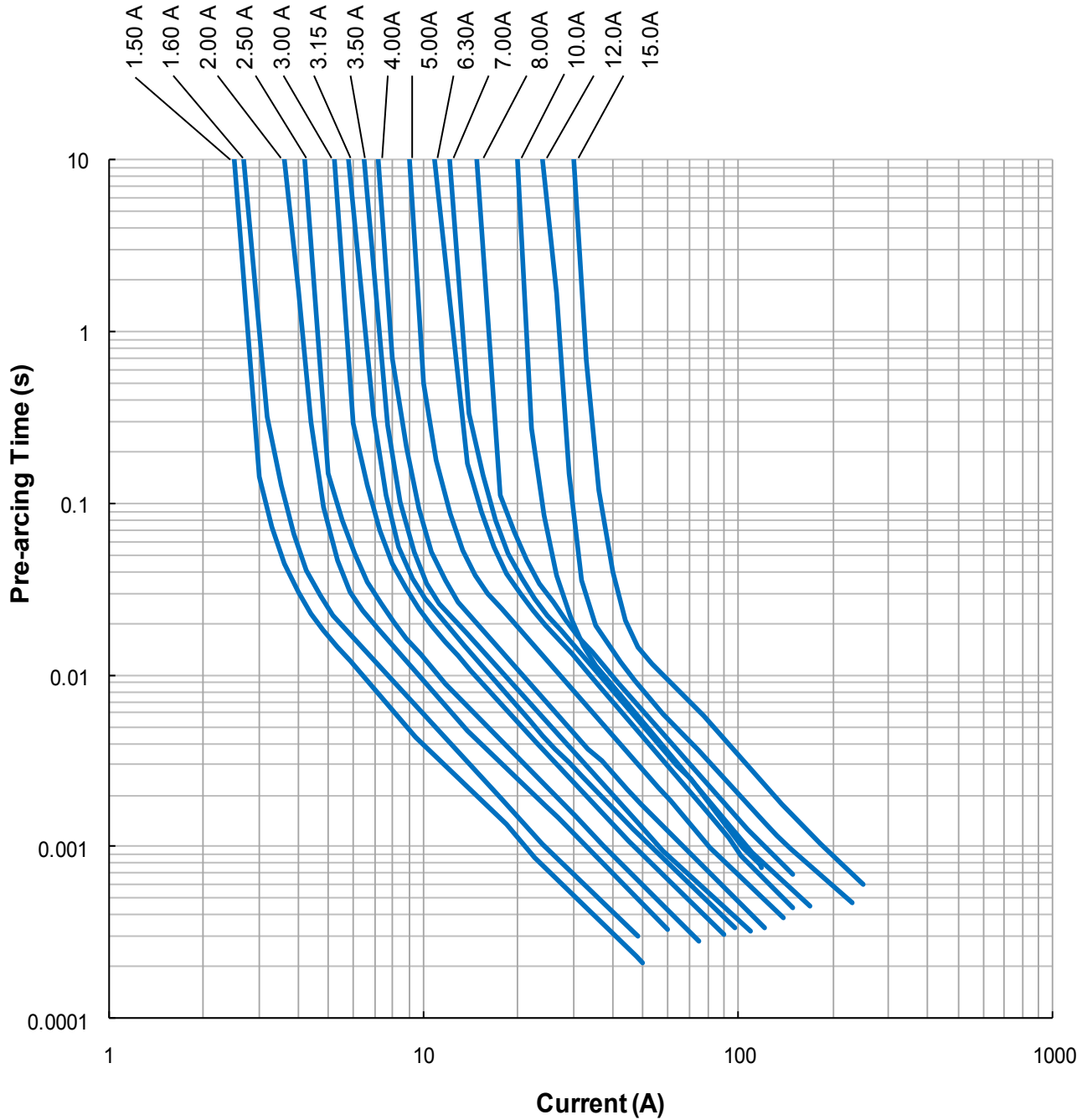

AirMatrix[®] Surface Mount Fuses

AF Series, 1206 Size

Average I^2t vs. t Curves:

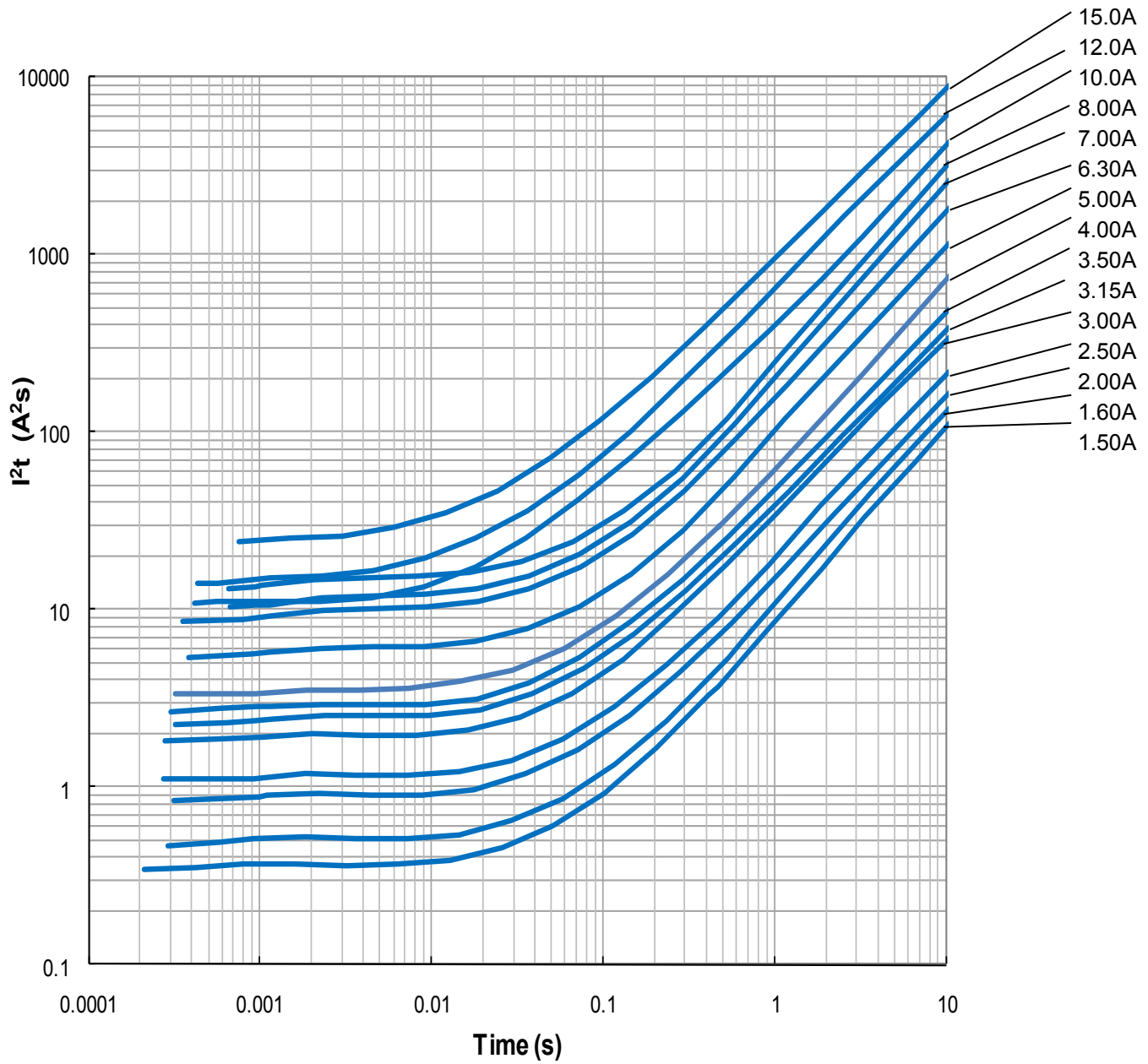

AirMatrix[®] Surface Mount Fuses

MF Series, 2410 Size



Features:

- Extremely small size with 250 VAC rating
- Surface mount fuses in AC applications
- Excellent inrush current withstanding capability
- Fiberglass enforced epoxy fuse body
- Copper termination with nickel and tin plating
- 100% lead-free
- Operating temperature range: -55°C to +125 °C (with de-rating)
- Compliant with IEC 60127-4

Application Fields:

- Lighting: Ballast, LED Drivers
- Power: Chargers, Adapters, Power Boards
- Medical Equipment
- Industrial Equipment
- White Goods

Shape and Dimensions:

	Inch	mm
L	0.240 ± 0.006	6.10 ± 0.15
W	0.098 ± 0.006	2.49 ± 0.15
H	0.085 ± 0.008	2.16 ± 0.20
BW	0.053 ± 0.015	1.35 ± 0.38
P	≥ 0.118	≥ 3.00

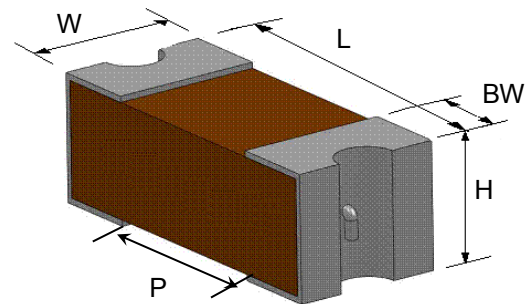

Clearing Time Characteristics:

% of Current Rating	Clearing Time at 25°C	
	Min.	Max.
125%	1 hour	
200%		120 seconds
1000%	0.001 seconds	0.01 seconds

Agency Approval:

Agency	File No.
UL	E232989
CQC	CQC11012065956
KC	SU05038-12001/12002
PSE	PSE12020434
VDE	40034853

Patents:

Patent numbers "ZL200810092353.3", "ZL200910007157.6", "ZL201120450579.3", "ZL201120536307.5", "ZL201220063222.4", "ZL201110123326.X".

AirMatrix[®] Surface Mount Fuses

MF Series, 2410 Size

Ordering Information:

Part Number	Current Rating (A)	Voltage Rating (VAC)	Interrupting Ratings	Nominal DCR (Ω)	Voltage Drop Max. (mV)	Nominal I^2t (A^2s)	Marking (Black)
MF2410F0.500TM	0.50	250	100 A @ 250 VAC 50 A @ 125 VDC	0.206	166	0.11	C
MF2410F0.630TM	0.63	250		0.148	144	0.20	S
MF2410F0.800TM	0.80	250		0.109	139	0.35	H
MF2410F1.000TM	1.00	250		0.084	129	0.62	E
MF2410F1.250TM	1.25	250		0.065	128	1.00	F
MF2410F1.600TM	1.60	250		0.049	127	1.80	T
MF2410F2.000TM	2.00	250		0.038	123	3.00	I

Notes:

- Resistance is measured at $\leq 10\%$ of rated current and 25°C ambient.
- Voltage drop is measured at 100% of rated current.
- Melting I^2t is calculated at 0.001 second pre-arcing time.

AirMatrix[®] Surface Mount Fuses

MF Series, 2410 Size

Average Pre-arcing Time Curves:

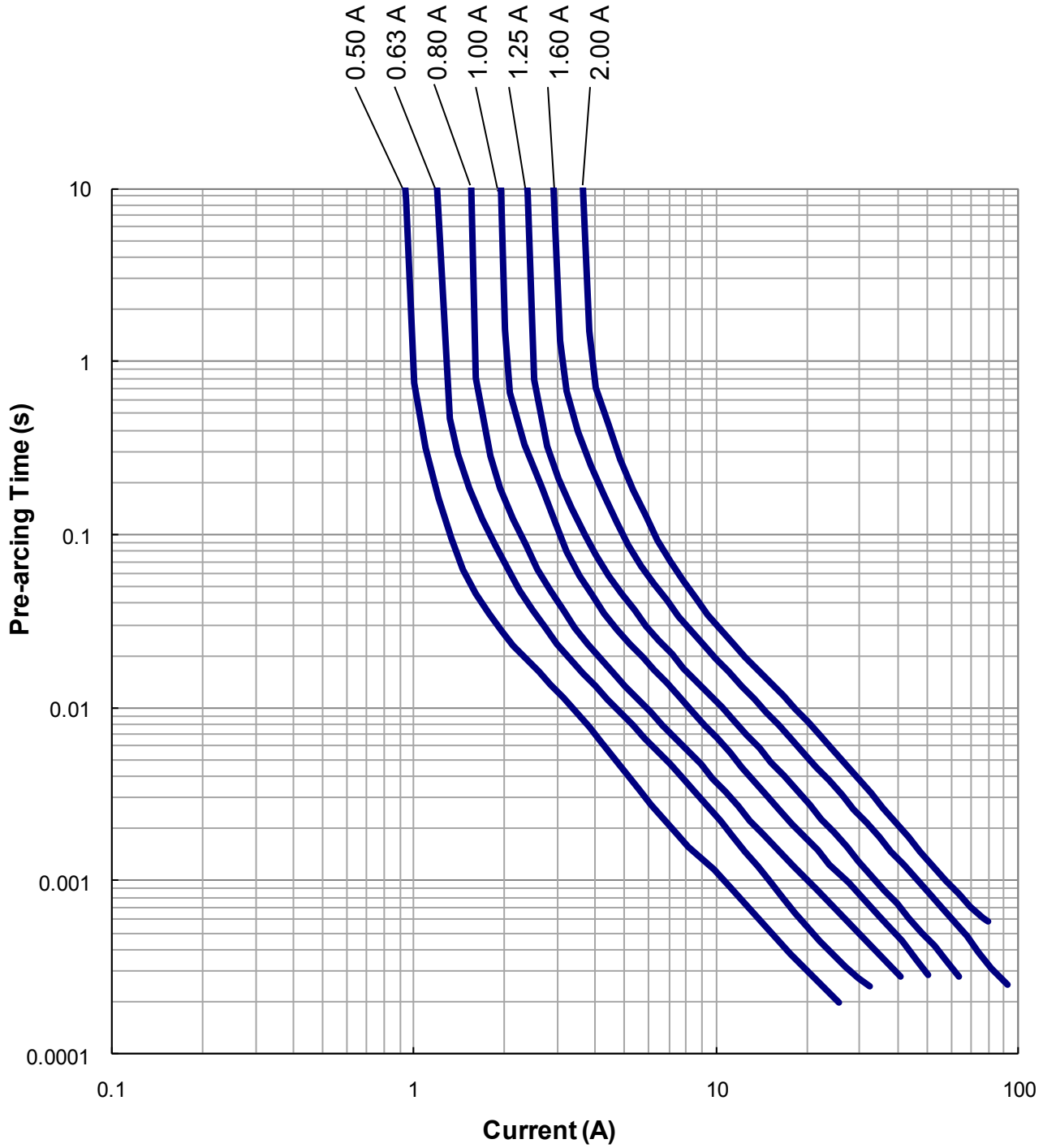

AirMatrix[®] Surface Mount Fuses

MF Series, 2410 Size

Average I^2t vs. t Curves:

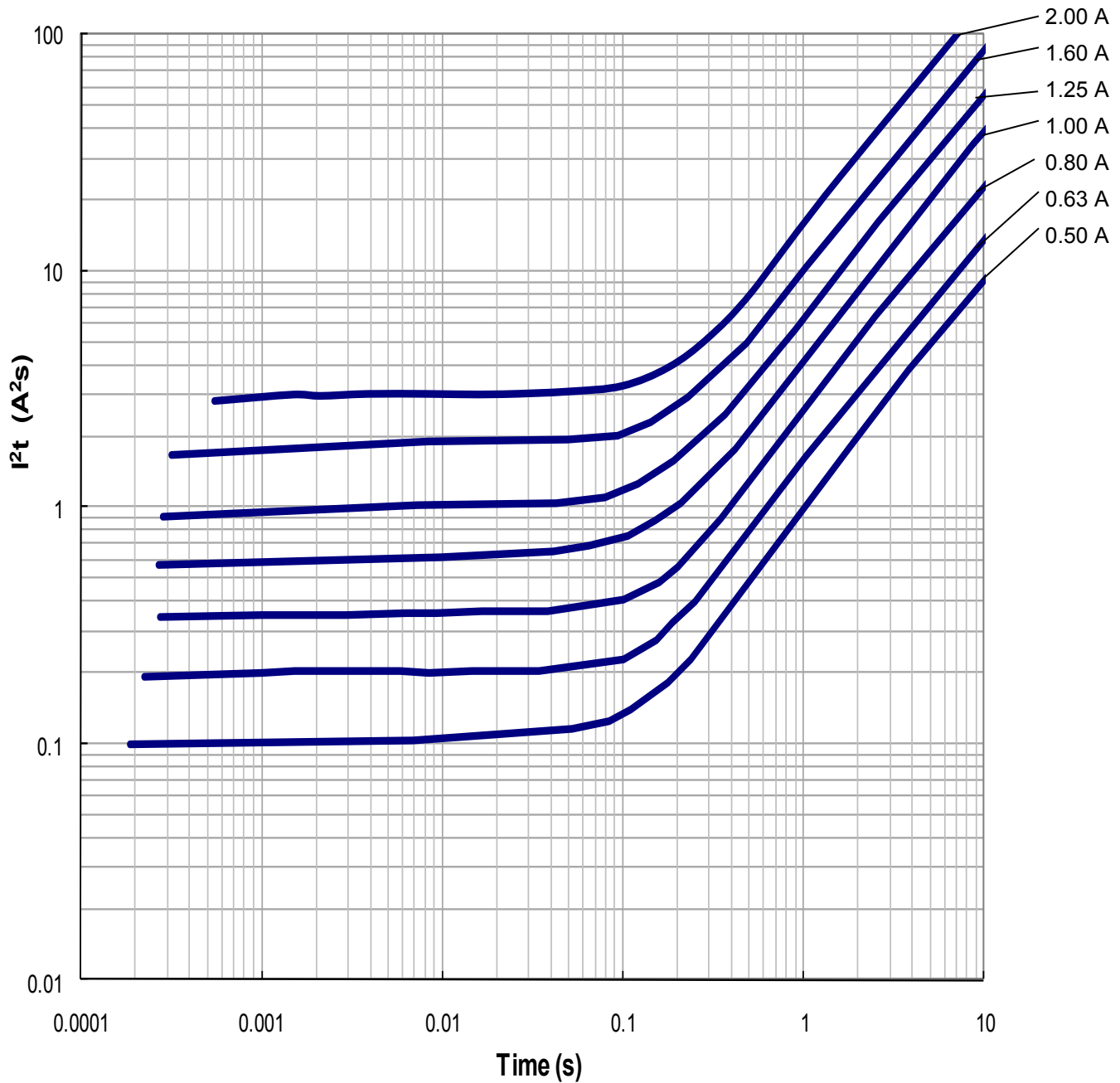

AirMatrix® Surface Mount Fuses

MF Series, 1210 Size



Features:

- Extremely small size with VAC rating
- Surface mount fuses in AC applications
- Excellent inrush current withstanding capability
- Operating temperature range: -55°C to +125°C (with de-rating)
- Fiberglass enforced epoxy fuse body
- Copper termination with nickel and in plating
- Halogen free, RoHS compliant
- 100% lead-free

Typical Application:

- Lighting and Driver
- Low Voltage Power and Charger
- Application
- Industrial Equipment
- White Goods

Clearing Time Characteristics:

% of current rating	Clearing time at 25°C
100%	4 hours min.
250%	5 seconds max.

Agency Approval:

Recognized Under the Components Program of UL.
File Number: E232989.

Patents:

Patent numbers "ZL200810092353.3", "ZL200910007157.6",
"ZL201120450579.3", "ZL201120536307.5",
"ZL201220063222.4", "ZL201110123326.X".

Ordering Information:

Part Number	Current Rating (A)	Voltage Rating (VAC)	Interrupting Ratings	Nominal Cold DCR (Ω) ¹	Nominal I^2t (A^2s) ²	Marking (Black)
MF1210F1.00TM	1.00	125	100 A @ 125 VAC 100 A @ 65 VDC	0.079	0.2	E
MF1210F1.50TM	1.50			0.050	0.5	G
MF1210F2.00TM	2.00			0.037	0.9	I
MF1210F2.50TM	2.50			0.033	1.2	J
MF1210F3.00TM	3.00			0.028	1.5	K

Notes:

- Resistance is measured at $\leq 10\%$ of rated current and 25°C ambient.
- I^2t is measured at 0.001s.

Shape and Dimensions:

Unit	Inch	mm
L	0.126 + 0.016/-0	3.20 + 0.40/-0
W	0.098 ± 0.008	2.50 ± 0.20
H	0.063 ± 0.008	1.60 ± 0.20
BW	0.033 ± 0.012	0.85 ± 0.30
P	≥ 0.063	≥ 1.6

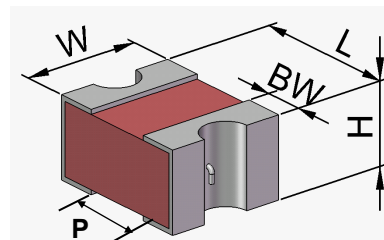

AirMatrix[®] Surface Mount Fuses

MF Series, 1210 Size

Average Pre-arcing Time Curves:

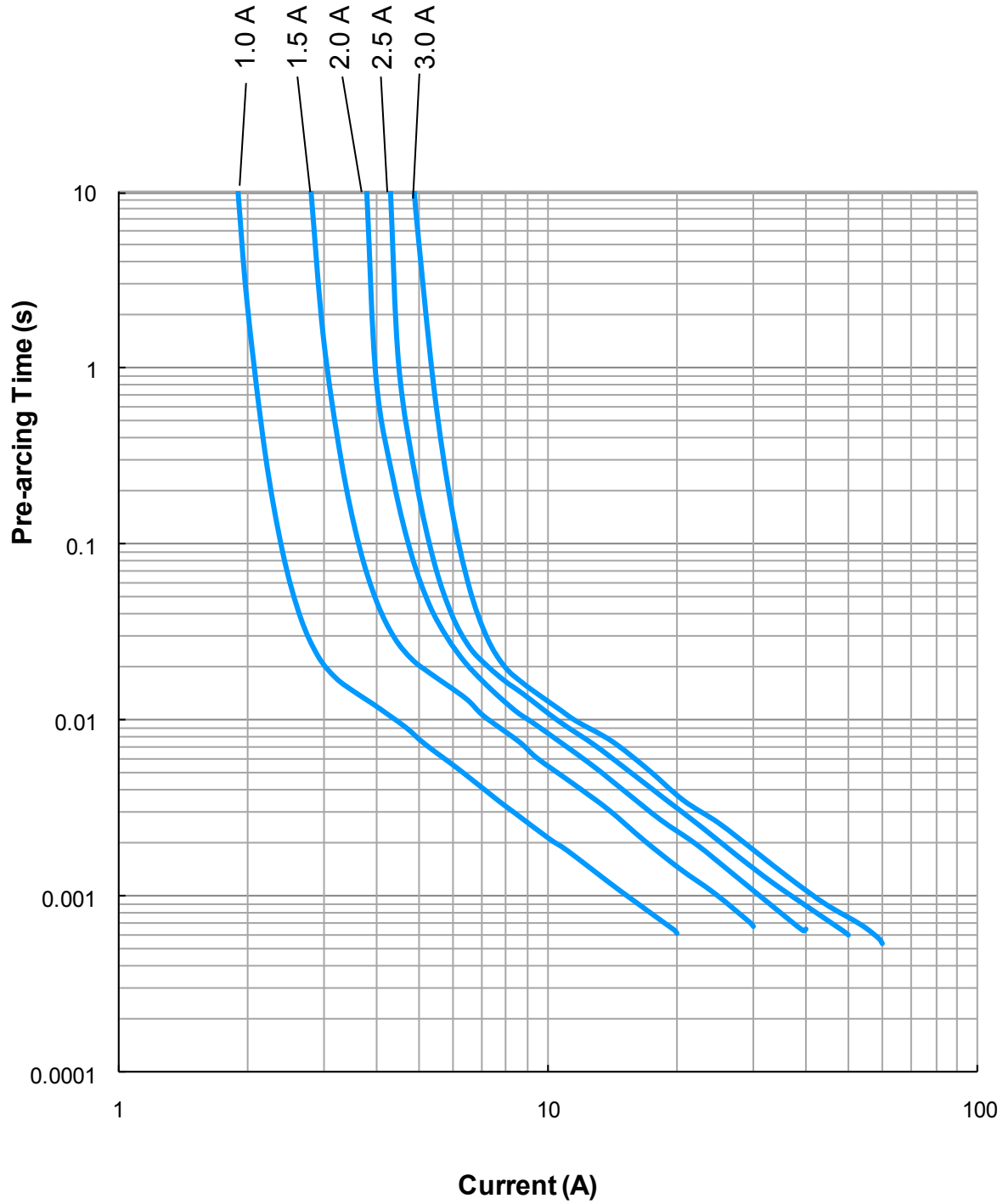

AirMatrix[®] Surface Mount Fuses

MF Series, 1210 Size

Average I^2t vs. t Curves:

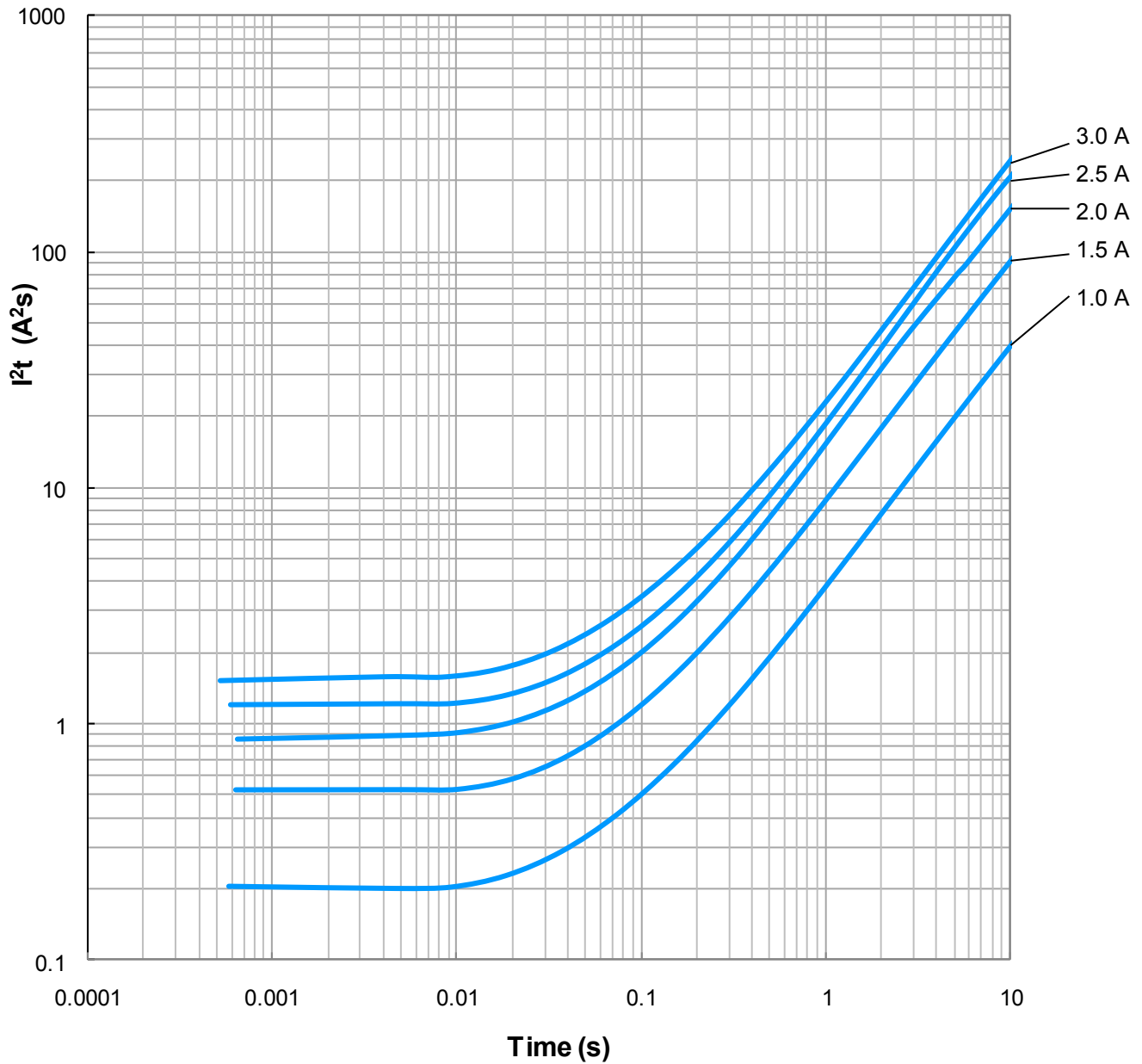

ESD Suppressors

Quick Index:

	Series	Size	Capacitance (1 GHz)	Page
Surface Mount ESD Suppressors	GcDiode® ESD Suppressors	0603, 0402	0.25 pF (typical)	75
	PeDiode® ESD Suppressors	0402	0.05 pF (typical)	78
	ESD Suppressor Array	1004	0.1 pF (typical)	82
Surface Mount TVS Diodes	ESD Protection Diode	0201	3 pF (typical)	86
		0402	10 pF (typical)	88
	Ultra Low Capacitance ESD Protection Diode	0402	0.3 pF (typical)	90
	ESD Protection Diode Array	1004	0.25 pF (typical)	92

Surface Mount ESD Suppressors

Recommended Reflow Soldering Profile:

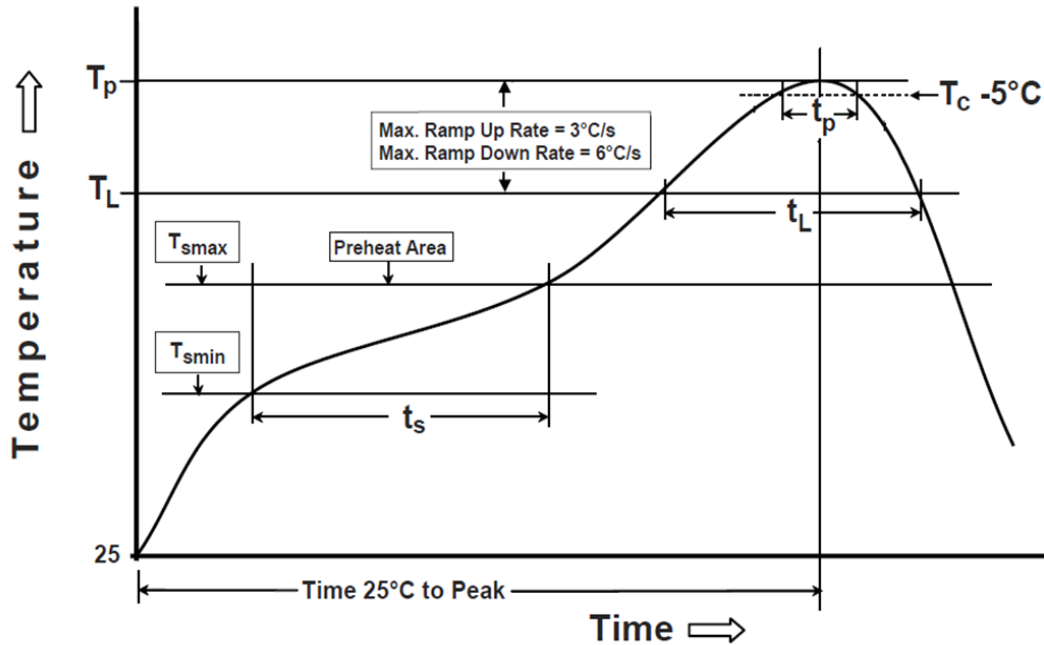

Profile Feature	Pb-Free Assembly
Preheat/Soak Temperature Min (T_{smin}) Temperature Max (T_{smax}) Time (t_s) from (T_{smin} to T_{smax})	150°C 200°C 60~120 seconds
Ramp-up rate (T_L to T_p)	3°C/second max.
Liquidous temperature (T_L) Time (t_L) maintained above T_L	217°C 60~150 seconds
Peak package body temperature (T_p)	260°C
Time (t_p)* within 5°C of the specified classification temperature (T_c)	30 seconds *
Ramp-down rate (T_p to T_L)	6°C/second max.
Time 25°C to peak temperature	8 minutes max.
* Tolerance for peak profile temperature (T_p) is defined as a supplier minimum and a user maximum	

Recommended Conditions for Hand Soldering:

1. Appropriate temperature (max.) of soldering iron tip/soldering time (max.): 280°C/10s or 350°C/ 3s.
2. Using hot air rework station with tip that can melt the solder on both terminations at the same time is strongly recommended. Do

Surface Mount ESD Suppressors

GcDiode[®] ESD Suppressors



Features:

- Glass ceramic monolithic structure
- Ultra low capacitance (0.25 pF typical)
- Low leakage current (<0.1 nA)
- Fast response time (<1 ns)
- Bi-directional flip-chip design
- Low clamping voltage
- Silver termination with nickel and tin plating
- Withstands multiple 8 kV ESD strikes
- 100% lead-free and RoHS compliant

Electrical Characteristics:

Characteristic	Value
IEC61000-4-2 Direct Discharge	Level 4 – 8 kV
IEC61000-4-2 Air Discharge	Level 4 – 15 kV
Trigger Voltage	300 V (typical) (measured per IEC61000-4-2, Level 4, 8 kV)
Clamping Voltage	30 V (typical) (measured per IEC61000-4-2, Level 4, 8 kV)
Response Time	Less than 1 ns
Capacitance (1 GHz)	0.25 pF (typical)
Leakage Current	Less than 0.1 nA (typical) (measured at 14 VDC)
Rated Voltage	14 VDC (max.)
ESD Pulse Withstand	1000 Pulses (typical)

Shape and Dimensions:

Size	L	W	T	BW
0402 (1005)	0.039 ± 0.004 (1.00 ± 0.10)	0.020 ± 0.004 (0.51 ± 0.10)	0.020 ± 0.004 (0.51 ± 0.10)	0.010 ± 0.004 (0.25 ± 0.10)
0603 (1608)	0.063 ± 0.006 (1.60 ± 0.15)	0.031 ± 0.006 (0.80 ± 0.15)	0.031 ± 0.006 (0.80 ± 0.15)	0.014 ± 0.006 (0.36 ± 0.15)

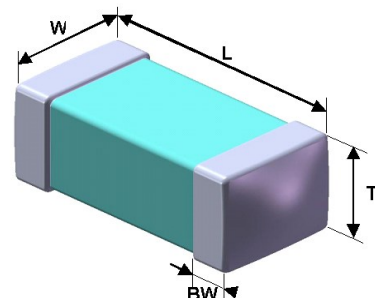

Surface Mount ESD Suppressors

GcDiode[®] ESD Suppressors

Recommended PC Board Land Pattern:

Chip Size	L Inch (mm)	G Inch (mm)	H Inch (mm)
0402 (1005)	0.063 (1.60)	0.016 (0.40)	0.028 (0.70)
0603 (1608)	0.087 (2.20)	0.031 (0.80)	0.039 (1.00)

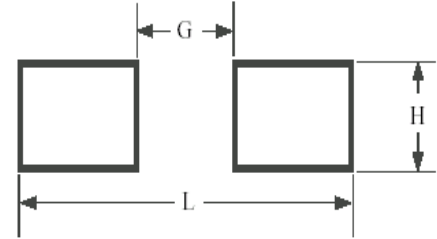

Product Identification:

ES 0603 V014 C I
 (1) (2) (3) (4) (5)

- (1) Category code
- (2) Dimension code: L x W (inch)
 The first two digits - L (length)
 The last two digits - W (width)
- (3) Rated voltage code: V014 -14 VDC
- (4) Series code
- (5) Package code:
 T - Tape & Reel
 B - Bulk

Representative Test Waveform Per IEC61000-4-2 Level 4, 8kV:

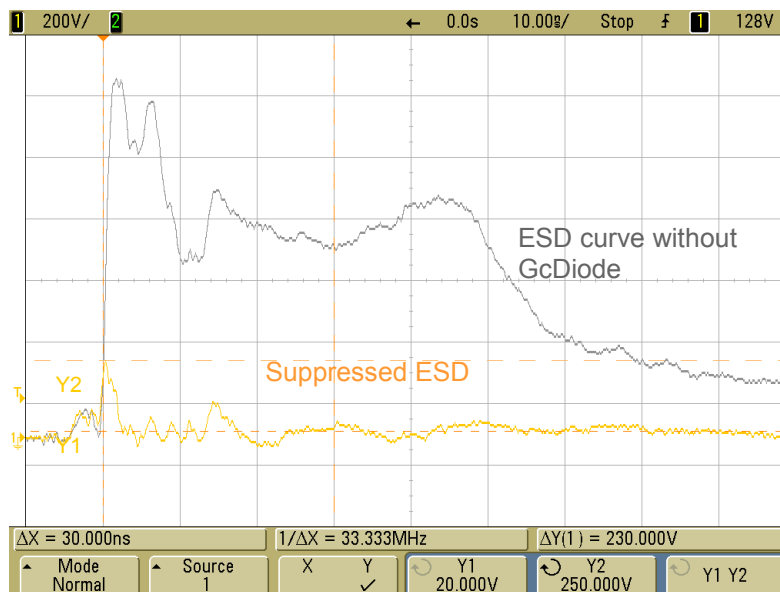

Surface Mount ESD Suppressors

GcDiode[®] ESD Suppressors

Reliability Tests:

Reliability Test	Test Conditions and Requirements	Test Reference
Flexure Strength	2 mm bend, meet triggering voltage and clamping voltage requirements while being bent, and meet leakage current requirement after bending.	IEC60068-2-21
Solderability	255°C, 5 seconds 90% coverage min.	MIL-STD-202 Method 208
Soldering Heat Resistance	260°C, 10 seconds No mechanical damage Pass ESD test.	MIL-STD-202 Method 210
Thermal Shock	100 cycles between -65°C and +125°C No mechanical damage Pass ESD test	MIL-STD-202 Method 107
Mechanical Vibration	0.4" D.A. or 30 G between 5-3000 Hz No mechanical damage Pass ESD test	MIL-STD-202 Method 204
Mechanical Shock	1500 G, 0.5 ms, half-sine shocks No mechanical damage Pass ESD test	MIL-STD-202 Method 213
Salt Spray	48 hour exposure No excessive corrosion Pass ESD test	MIL-STD-202 Method 101
Moisture Resistance	10 cycles No excessive corrosion Pass ESD test	MIL-STD-202 Method 106
Endurance	85°C, 1000 hours, rated voltage Leakage current less than 100 nA	Refer to AEM QIQ159

Packaging Data:

Chip Size	Parts on 7 inch (178 mm) Reel
0402 (1005)	10,000
0603 (1608)	4,000

Surface Mount ESD Suppressors

PeDiode[®] ESD Suppressors, PS0402V014AT

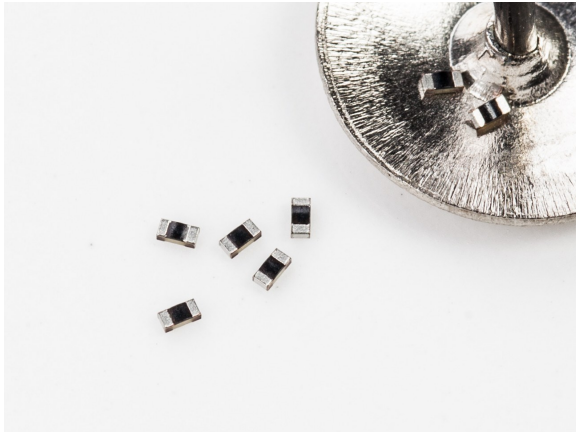

Features:

- Excellent protection against ESD damage
- Ultra low capacitance for high speed data lines (<0.1 pF)
- Low typical leakage current (<10 nA)
- Fast response time (<1 ns)
- Excellent 4KV trigger capability (100%)
- Bi-directional design
- Lead free and halogen free polymer composite materials
- RoHS compliant
- Operating temperature $-55^{\circ}\text{C} \sim +90^{\circ}\text{C}$

Electrical Characteristics (@ 25°C):

Characteristic	Value
IEC61000-4-2 Direct Discharge	Level 4 – 8 kV
IEC61000-4-2 Air Discharge	Level 4 – 15 kV
Trigger Voltage	300 V typical
Clamping Voltage	25 V typical
Response Time	Less than 1 ns
Capacitance @ f = 1GHz	0.05 pF typical
Leakage Current @ 14 V _{DC}	10 nA max
Rated Voltage	14 V _{DC} max
ESD Pulse Withstand	1000 Pulses typical

Shape and Dimensions:

Size Inch/(mm)	L	W	T	BW
0402 (1005)	0.039±0.004 (1.00 ± 0.10)	0.020±0.004 (0.50 ± 0.10)	0.013±0.004 (0.33 ± 0.10)	0.009±0.004 (0.23 ± 0.10)

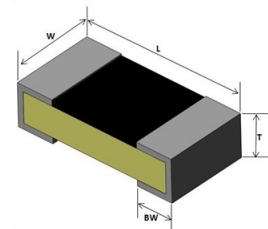

Surface Mount ESD Suppressors

PeDiode[®] ESD Suppressors, PS0402V014AT

Recommended Foot Print Dimensions:

Size Inch/(mm)	L	G	H
0402 (1005)	0.063 (1.60)	0.016 (0.40)	0.028 (0.70)

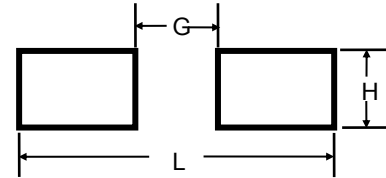

Product Identification:

PS 0402 V014 A I
 (1) (2) (3) (4) (5)

- (1) Category code
- (2) Dimension code: L x W (inch)
 The first two digits - L (length)
 The last two digits - W (width)
- (3) Rated voltage code: V014 - 14 V_{DC}
- (4) Series code
- (5) Package code: T - Tape & Reel

Representative Test Waveform Per IEC61000-4-2 Level 4, 8kV Direct Discharge:



Surface Mount ESD Suppressors

PeDiode[®] ESD Suppressors, PS0402V014AT

Reliability Tests:

Reliability Test	Test Conditions and Requirements	Test Reference
Flexure Strength	2 mm bend, meet triggering voltage and clamping voltage requirements while being bent, and meet leakage current requirement after bending.	IEC60068-2-21
Solderability	245°C, 5 seconds 95% coverage min.	MIL-STD-202 Method 208
Thermal Shock	100 cycles between -65°C and +125°C No mechanical damage Pass ESD test	MIL-STD-202 Method 107
Mechanical Vibration	0.4" D.A. or 30 G between 5-3000 Hz No mechanical damage Pass ESD test	MIL-STD-202 Method 204
Mechanical Shock	1500 G, 0.5 ms, half-sine shocks No mechanical damage Pass ESD test	MIL-STD-202 Method 213
Salt Spray	48 hour exposure No excessive corrosion Pass ESD test	MIL-STD-202 Method 101
Moisture Resistance	10 cycles No excessive corrosion Pass ESD test	MIL-STD-202 Method 106
Endurance	1000 hours at +85°C under rated voltage Leakage current shall not exceed 100 nA	Refer to AEM QIQ159
High temperature and humidity load test	1000 hours at +85°C and 80~90%RH under rated voltage Leakage current shall not exceed 100 nA	Refer to AEM QIQ163

Packaging and Marking Information:

Package	Tape & Reel Quantity (piece)
0402 (1005)	15,000

Surface Mount ESD Suppressors

PeDiode[®] ESD Suppressors, PS0402V014AT

Recommended Reflow Soldering Profile:

Profile Feature	Pb-Free Assembly
Preheat/Soak	
Temperature Min (T_{smin})	150°C
Temperature Max (T_{smax})	200°C
Time (t_s) from (T_{smin} to T_{smax})	60~120 seconds
Ramp-up rate (T_L to T_p)	3°C/second max.
Liquidous temperature (T_L) Time (t_L) maintained above T_L	217°C 60~150 seconds
Peak package body temperature (T_p)	260°C
Time (t_p)* within 5°C of the specified classification temperature (T_c)	30 seconds *
Ramp-down rate (T_p to T_L)	6°C/second max.
Time 25°C to peak temperature	8 minutes max.
* Tolerance for peak profile temperature (T_p) is defined as a supplier minimum and a user maximum	

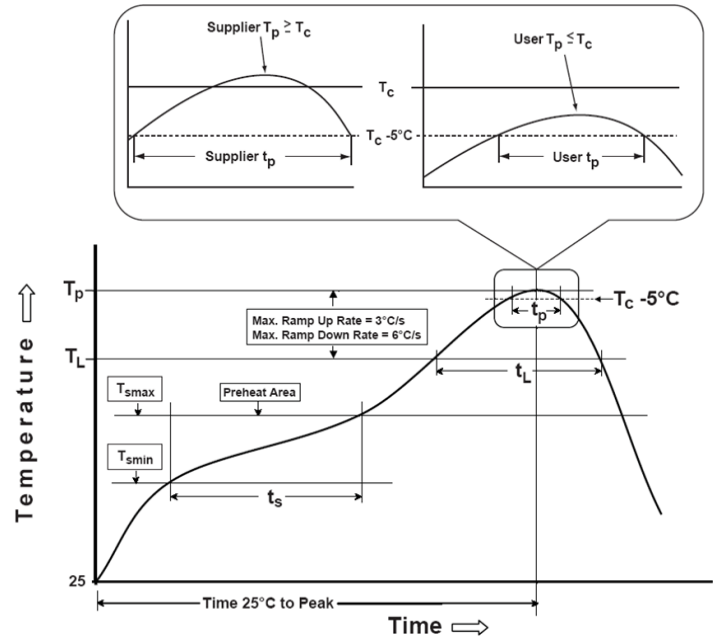

Recommended conditions for hand soldering:

1. Appropriate temperature (max.) of soldering iron tip/soldering time (max.): 280°C/10s or 350°C/ 3s. Using hot air rework station with tip that can melt the solder on both terminations at the same time is strongly recommended. Do not directly contact the chip termination with the tip of soldering iron.

Storage Condition With Package:

- The maximum ambient temperature shall not exceed 35°C. Storage temperature higher than 35°C could result in the deformation of packaging materials.
- The maximum relative humidity recommended for storage is 75%. High humidity with high temperature could accelerate the oxidation of the solder plating on the termination and reduce the solderability of the components.
- Sealed plastic bags with desiccant shall be used to reduce the oxidation of the termination and shall only be opened prior to use.
- The products shall not be stored in areas where harmful gases containing sulfur or chlorine are present.

Surface Mount ESD Suppressors

Surface Mount ESD Suppressor Array, EC1004L4V012AT

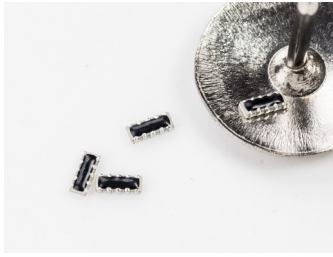

Application:

- Antenna circuit
- DVI
- USB2.0/3.0
- HDMI1.3/1.4
- IEEE-1394

Features:

- Extremely quick response time (<1ns) present ideal ESD protection
- Extremely low capacitance (0.1pF typical)
- Extremely low leakage current (0.01 μ A)
- Zero signal distortion
- SMD (Surface Mount Device)
- Protection against ESD voltages and currents (IEC61000-4 -2 Level 4)
- Lead free, RoHS Compliance
- Operating temperature -55°C ~ +125°C
- Storage temperature range -55°C ~ +125°C

Recommended Foot Print Dimensions:

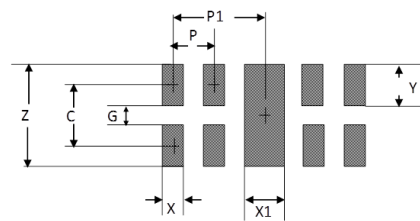

Unit	Inch	mm
Y	0.024	0.6
G	0.008	0.2
Z	0.055	1.4
X	0.008	0.2
XL	0.012	0.3
P	0.020	0.5
P1	0.039	1.0
C	0.031	0.8

Shape and Dimensions:

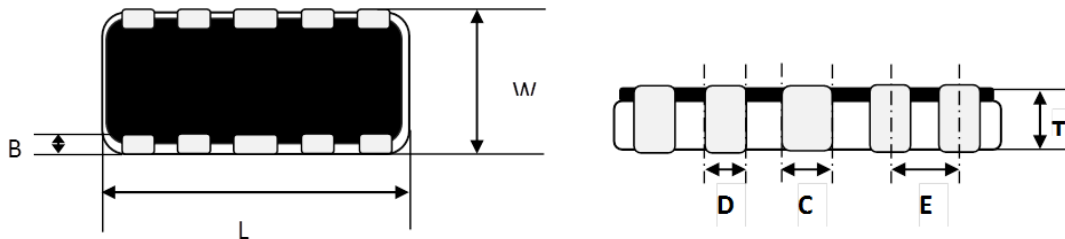

Size Inch/(mm)	L	W	T	B	C	D	E
1004 (2510)	0.098±0.004 (2.5±0.1)	0.039±0.004 (1.0±0.1)	0.020±0.004 (0.5±0.1)	0.008±0.004 (0.2±0.1)	0.012±0.002 (0.3±0.05)	0.008±0.002 (0.2±0.05)	0.020±0.002 (0.5±0.05)

Circuit Symbol:

Pin	Description
1,2,4,5	Data Lines
6,7,9,10	Data Lines (No Internal Connection)
3,8	Ground

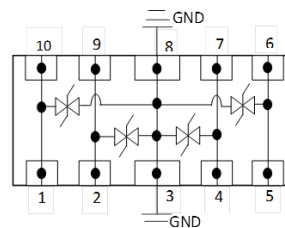

Packaging Information:

Package	Tape & Reel Quantity (piece)
1004 (2510)	5,000

Storage Conditions:

Storage Time: 12 months max
 Storage Temperature : 5°C to 30°C
 Relative Humidity: < 60% RH

Surface Mount ESD Suppressors

Surface Mount ESD Suppressor Array, EC1004L4V012AT

Electrical Characteristics (@25°C):

Characteristic	Value
IEC61000-4-2 Direct Discharge IEC61000-4-2 Air Discharge	Level 4 - 10 kV Level 4 - 15 kV
Trigger Voltage	300 V typical (measured per IEC61000-4-2, 8kV Direct Discharge)
Clamping Voltage	30 V typical (measured per IEC61000-4-2, 8kV Direct Discharge)
Response Time	Less than 1 ns
Capacitance @ f = 1MHz	0.1 pF typical
Leakage Current @ 12 V _{DC}	0.01 μA max.
Rated Voltage	12 V _{DC} max.
ESD Pulse Withstand	1000 Pulses typical

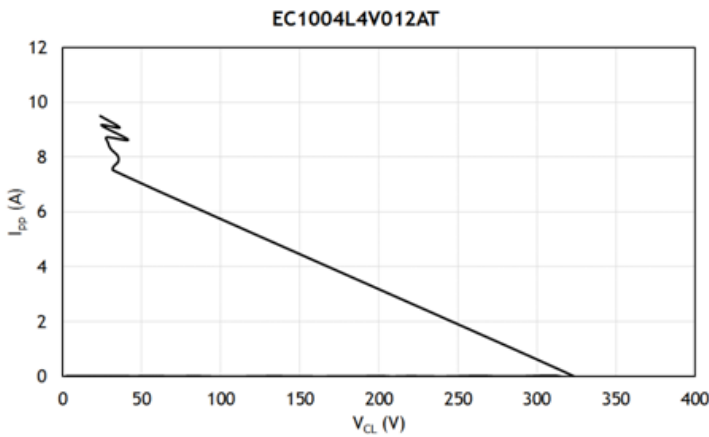

Fig. 1
Dynamic resistance with positive clamping voltage
 $t_p = 100\text{ns}$; Transmission Line Pulse (TLP)

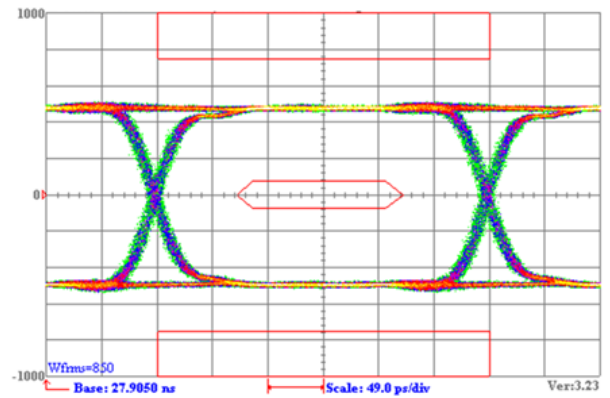

Fig. 1
Eye Diagram (HDMI 1.3)

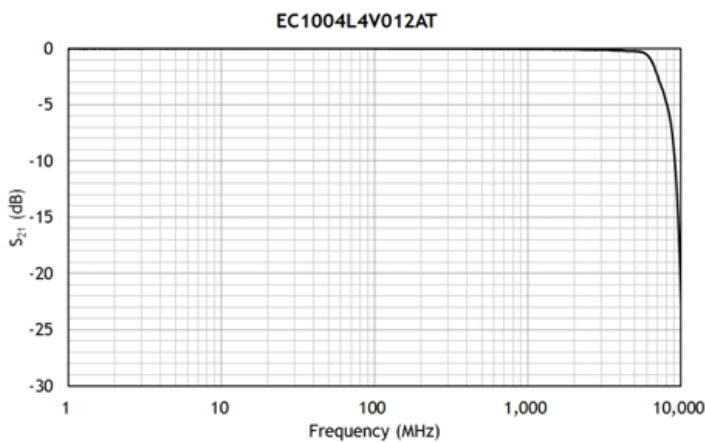
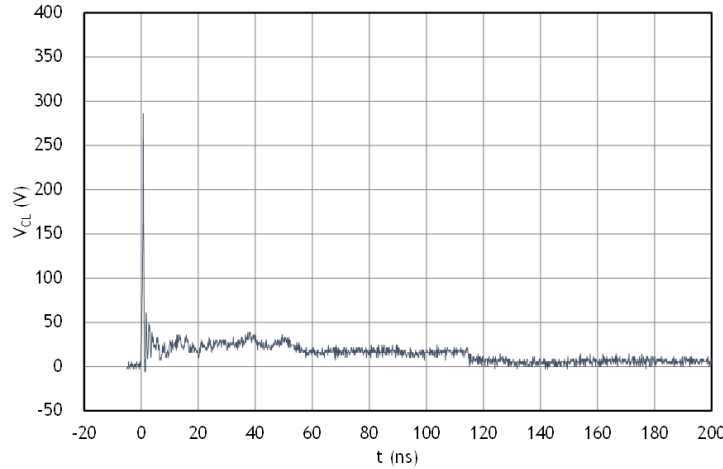

Fig. 3 Insertion loss; typical value

Surface Mount ESD Suppressors

Surface Mount ESD Suppressor Array, EC1004L4V012AT

Representative Test Waveform Per IEC61000-4-2 Level 4, 8kv Direct Discharge:



HDMI Interface Application:

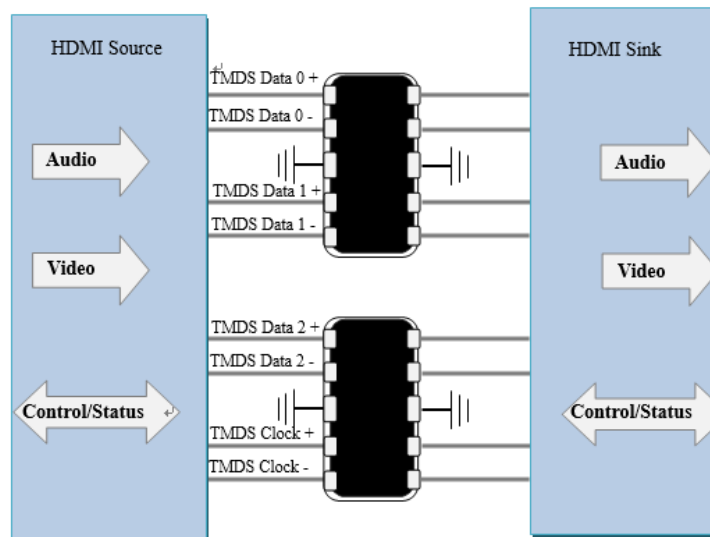
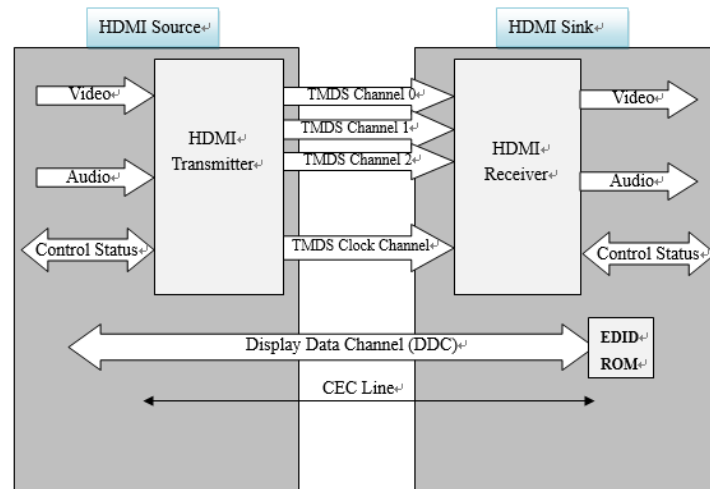

Surface Mount TVS Diodes

Shape and Dimensions:

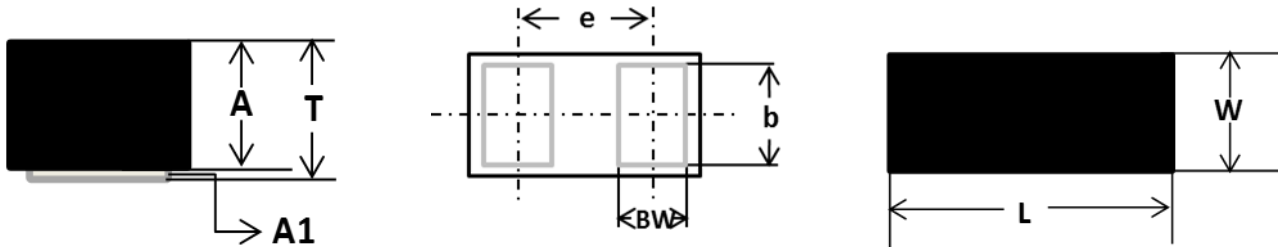

Package	Size inch/(mm)							
	L	W	T	BW	b	e	A	A1
0201 (DN0603)	0.024±0.002 (0.60±0.05)	0.013±0.002 (0.32±0.05)	0.012±0.002 (0.30±0.05)	0.006±0.002 (0.15±0.05)	0.010±0.002 (0.25±0.05)	0.015 (0.38)	0.011±0.002 (0.29±0.05)	0.0004 (0.01)
0402 (DFN1006)	0.039±0.002 (1.00±0.05)	0.024±0.002 (0.60±0.05)	0.020±0.002 (0.50±0.05)	0.014±0.002 (0.35±0.05)	0.020±0.002 (0.50±0.05)	0.026 (0.65)	0.019±0.002 (0.49±0.05)	0.0004 (0.01)

Packaging Information:

Package	Tape & Reel Quantity (piece)	Marking
0201 (DFN0603)	15,000	I
0402 (DFN1006)—TS04021C05V100	10,000	E5
0402 (DFN1006)—TS04021C05VR30	10,000	S
1004 (DFN2510)	3,000	P424

Storage Conditions:

Storage Time: 12 months max
 Storage Temperature : 5°C to 30°C
 Relative Humidity: < 60% RH

Surface Mount TVS Diodes

ESD Protection Diode, TS02011C05V3R0

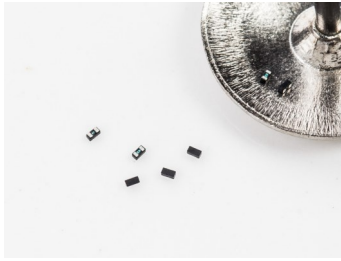

Application:

- Cellular handsets and accessories
- Portable electronics
- Computers and peripherals
- Communication systems
- Audio and video equipment

Features:

- Bi-directional ESD protection of one line
- Low capacitance (3 pF typical)
- IEC 61000-4-2, level 4 (ESD) protection
- Ultra small SMD special package (0201)
- Pb-Free, Halogen free/BFR free and RoHS compliant
- Operating temperature range $-55^{\circ}\text{C}\sim+125^{\circ}\text{C}$
- Storage temperature range $-55^{\circ}\text{C}\sim+150^{\circ}\text{C}$

Recommended Foot Print Dimensions:

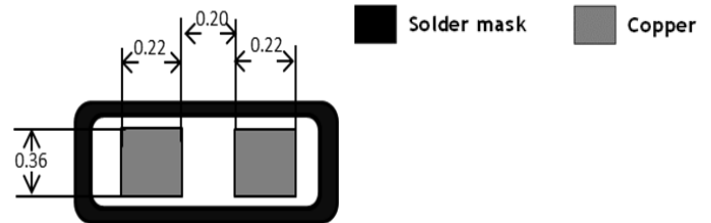

Electrical Characteristics (@25°C):

Characteristic	Condition	Value		
		Min.	Typical	Max.
ESD per IEC61000-4-2 Direct Discharge			± 8 kV	
ESD per IEC61000-4-2 Air Discharge			± 15 kV	
Peak Pulse Power (P_{PK})			75 W	
Reverse Stand-Off Voltage (V_{RWM})				5 V
Reverse Breakdown Voltage (V_{BV})	$I_{BV} = 1\text{mA}$	5.6 V		9 V
Clamping Voltage (V_{CL})	$I_{PP} = 1\text{A}, t_P = 8/20\mu\text{s}$			12 V
	$I_{PP} = 5\text{A}, t_P = 8/20\mu\text{s}$			15 V
Junction Capacitance (C_J)	$V_{RWM} = 0\text{V}, f = 1\text{MHz}$		3 pF	
Reverse Leakage Current (I_{RM})	$V_{RWM} = 5\text{V}$			1 μA

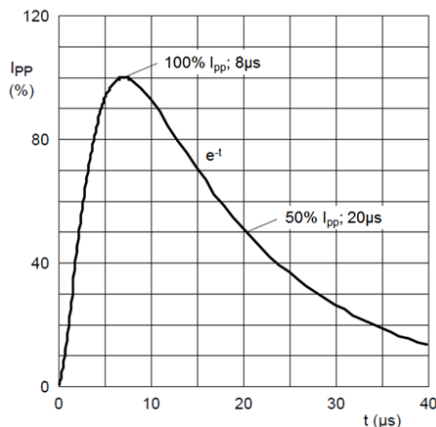

Fig. 1
8/20 μs pulse waveform
according to IEC 61000-4-5

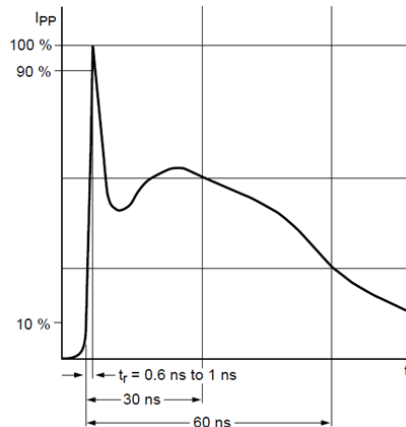

Fig. 2
ESD pulse waveform
according to IEC 61000-4-2

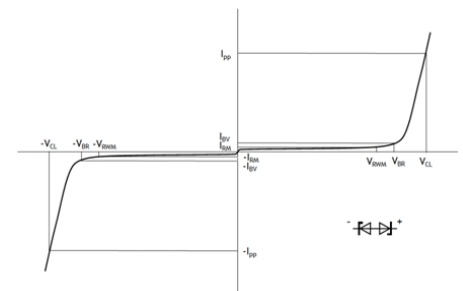
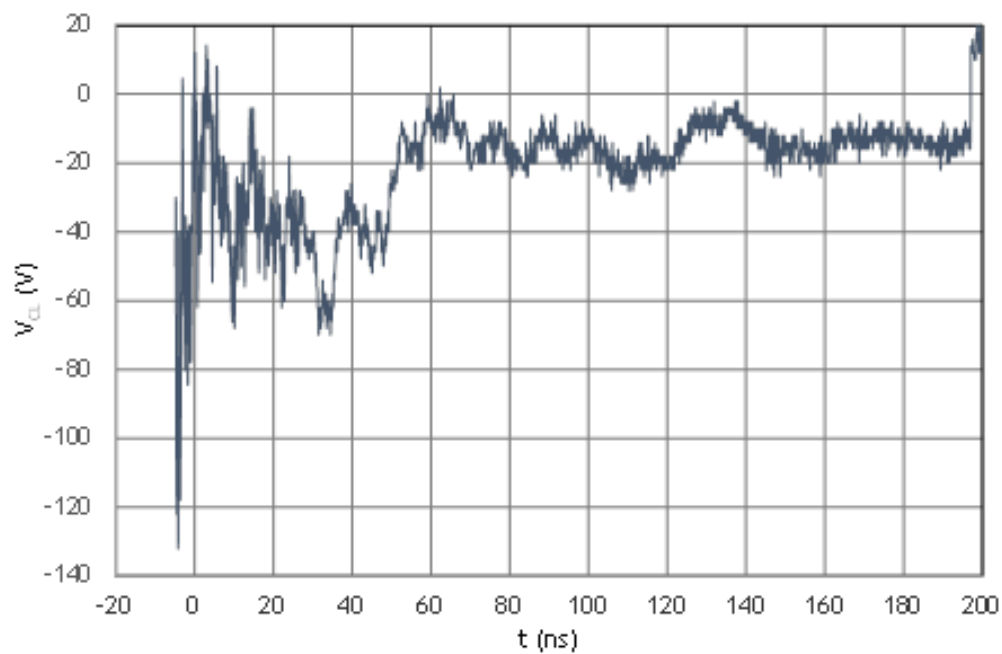
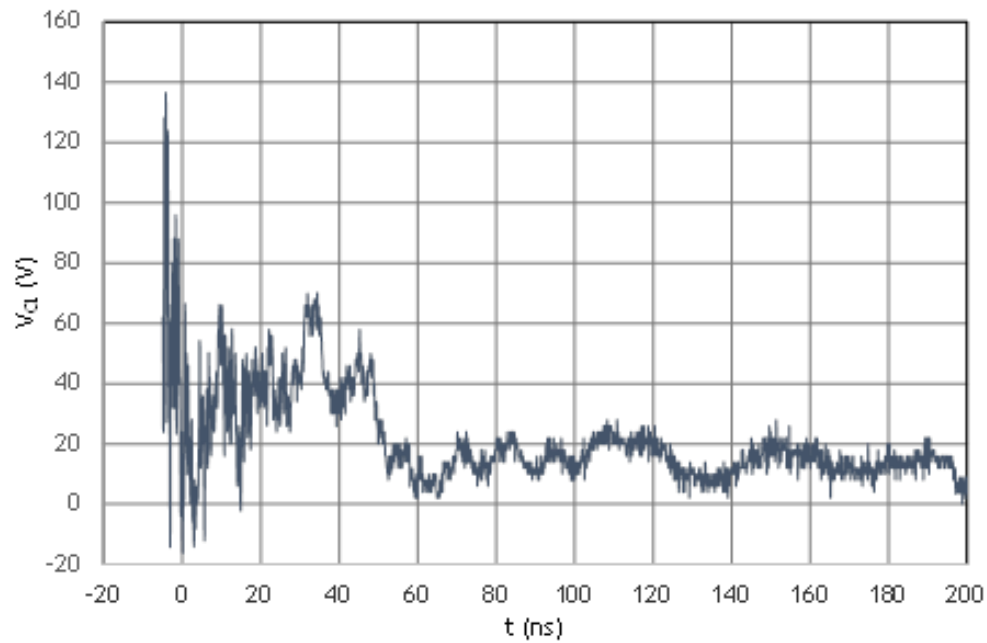

Fig. 3
V-I characteristics for bidirectional ESD
protection diode

Surface Mount TVS Diodes

ESD Protection Diode, TS02011C05V3R0

Clamped Pulse Waveform per IEC61000-4-2 Level 4, $\pm 8\text{kv}$ Direct Discharge:



Surface Mount TVS Diodes

ESD Protection Diode, TS04021C05V100



Application:

- Cellular handsets and accessories
- Portable electronics
- Computers and peripherals
- Communication systems
- Audio and video equipment

Features:

- Bi-directional ESD protection of one line.
- IEC 61000-4-2, level 4 (ESD) protection
- Ultra small SMD special packages (0402)
- Pb-Free, Halogen free and RoHS compliant
- Operating junction temperature $-55^{\circ}\text{C}\sim+125^{\circ}\text{C}$
- Storage temperature range $-55^{\circ}\text{C}\sim+150^{\circ}\text{C}$

Recommended Foot Print Dimensions:

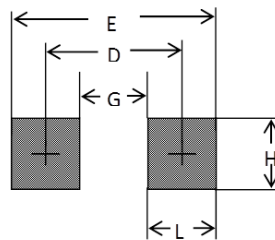

Unit	Inch	mm
L	0.020	0.50
G	0.010	0.25
H	0.028	0.70
D	0.030	0.75
E	0.049	1.25

Electrical Characteristics (@25°C):

Characteristic	Condition	Value		
		Min.	Typical	Max.
ESD per IEC61000-4-2 Direct Discharge			± 8 kV	
ESD per IEC61000-4-2 Air Discharge			± 16 kV	
Peak Pulse Power (P_{PK})	$t_P = 8/20\mu\text{s}$		75 W	
Maximum Peak Pulse Current (I_{PP})	$t_P = 8/20\mu\text{s}$		5 A	
Reverse Stand-Off Voltage (V_{RWM})				5 V
Reverse Breakdown Voltage (V_{BV})	$I_{BV} = 1\text{mA}$	6 V		
Clamping Voltage (V_{CL})	$I_{PP} = 1\text{A}, t_P = 8/20\mu\text{s}$			9 V
	$I_{PP} = 5\text{A}, t_P = 8/20\mu\text{s}$			15 V
Junction Capacitance (C_J)	$V_{RWM} = 0\text{V}, f = 1\text{MHz}$		10 pF	
Reverse Leakage Current (I_{RM})	$V_{RWM} = 5\text{V}$			2 μA

Surface Mount TVS Diodes

ESD Protection Diode, TS04021C05V100

Electrical Characteristics (@25°C):

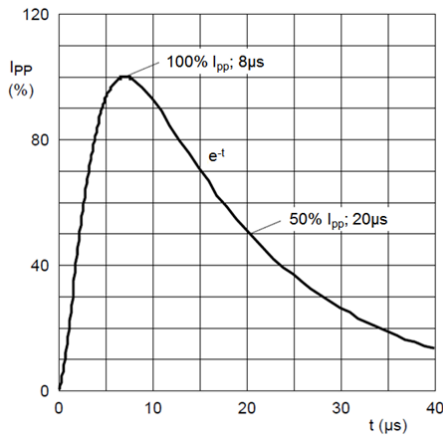

Fig. 1
8/20µs pulse waveform
according to IEC 61000-4-5

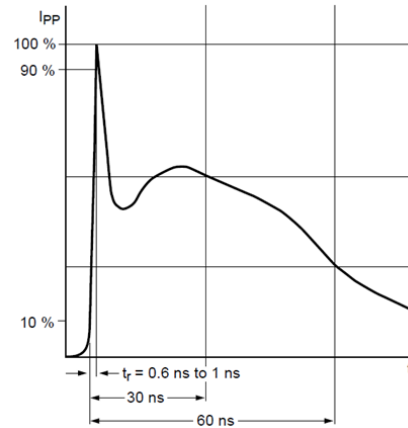

Fig. 2
ESD pulse waveform
according to IEC 61000-4-2

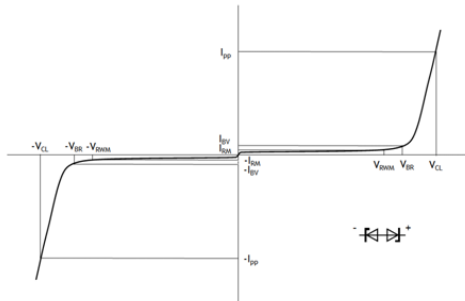

Fig. 3
V-I characteristics for bidirectional ESD
protection diode

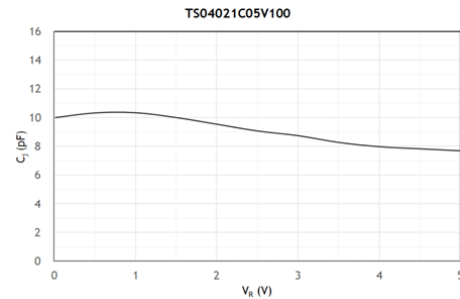

Fig. 4
Junction capacitance as a function of
reverse voltage; typical value

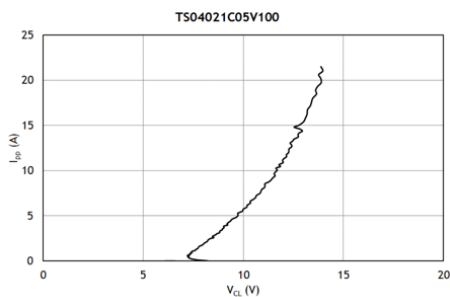

Fig. 5
Dynamic resistance with positive
clamping voltage $t_p = 10\text{ns}$;
Transmission Line Pulse (TLP)

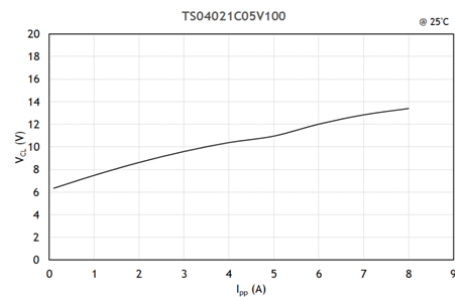

Fig. 6
Clamping voltage (V_{CL}) as a function of
peak current (I_{PP}); $t_p = 8/20\mu\text{s}$

Surface Mount TVS Diodes

Ultra Low Capacitance ESD Protection Diode, TS04021C05VR30



Application:

- Cellular handsets and accessories
- Portable electronics
- Notebooks, desktops and servers
- HDMI1.3/1.4, PCI express, SATA, USB 2.0, DVI, display port
- High-speed data lines

Features:

- Bi-directional ESD protection of one line.
- IEC 61000-4-2, level 4 (ESD) protection
- IEC61000-4-4 (EFT) rating - 40A (5/50 μ s)
- IEC61000-4-5 (Lightning) rating - 24A (8/20 μ s)
- Low capacitance (0.3pF typical)
- Ultra small SMD special packages (0402)
- Pb-Free, Halogen free and RoHS compliant
- Operating junction temperature -55°C~+125°C
- Storage temperature range -55°C~+150°C

Recommended Foot Print Dimensions:

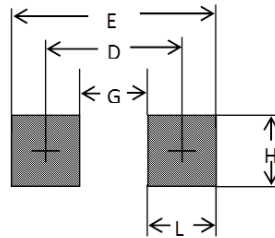

Unit	Inch	mm
L	0.020	0.50
G	0.010	0.25
H	0.028	0.70
D	0.030	0.75
E	0.049	1.25

Electrical Characteristics (@25°C):

Characteristic	Condition	Value		
		Min.	Typical	Max.
ESD per IEC61000-4-2 Direct Discharge			±8 kV	
ESD per IEC61000-4-2 Air Discharge			±16 kV	
Peak Pulse Power (P_{PK})	$t_p = 8/20\mu s$		30 W	
Reverse Stand-Off Voltage (V_{RWM})				5 V
Reverse Breakdown Voltage (V_{BV})	$I_{BV} = 1mA$	6.0 V	7.8 V	
Clamping Voltage (V_{CL})	$I_{PP} = 1A, t_p = 8/20\mu s$			14 V
Junction Capacitance (C_j)	$V_{RWM} = 0V, f = 1MHz$		0.3 pF	
Reverse Leakage Current (I_{RM})	$V_{RWM} = 5V$			1 μA

Surface Mount TVS Diodes

Ultra Low Capacitance ESD Protection Diode, TS04021C05VR30

Electrical Characteristics (@25°C):

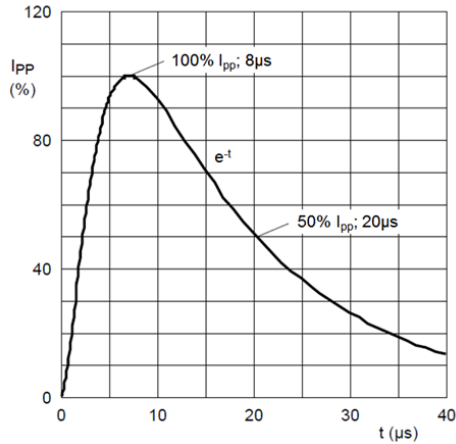

Fig. 1
8/20µs pulse waveform
according to IEC 61000-4-5

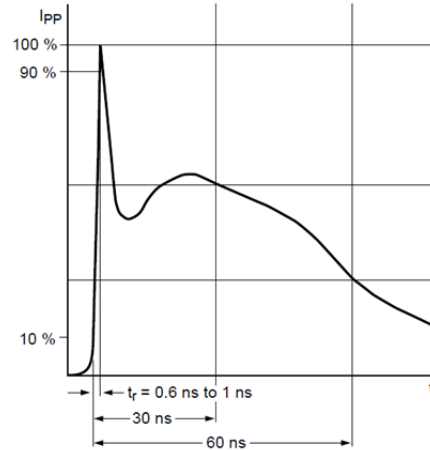

Fig. 2
ESD pulse waveform
according to IEC 61000-4-2

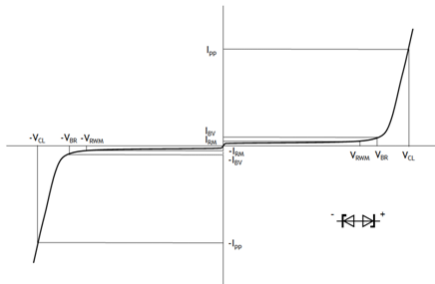

Fig. 3
V-I characteristics for bidirectional ESD
protection diode

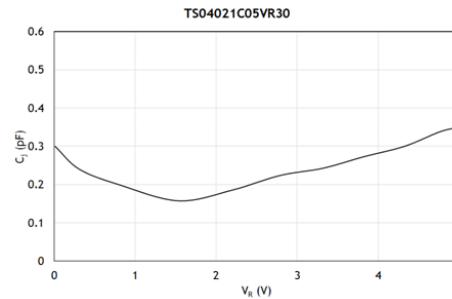

Fig. 4
Junction capacitance as a function of
reverse voltage; typical value

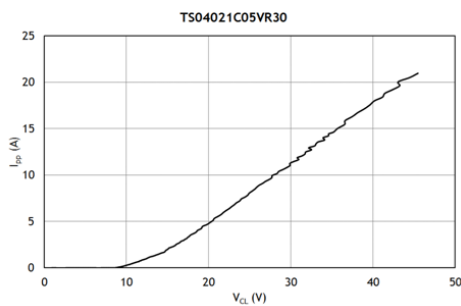

Fig. 5
Dynamic resistance with positive
clamping voltage $t_p = 10\text{ns}$;
Transmission Line Pulse (TLP)

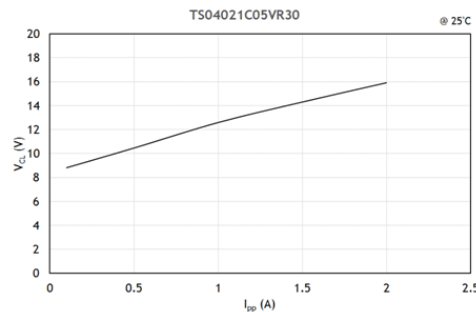

Fig. 6
Clamping voltage (V_{CL}) as a function of
peak current (I_{PP}); $t_p = 8/20\mu\text{s}$

Surface Mount TVS Diodes

ESD Protection Diode Array, TS10044C05VR25



Features:

- Protects four high speed I/O lines
- ESD protection for high-speed data lines to EC61000-4-2 (ESD) $\pm 17\text{kV}$ (air), $\pm 12\text{kV}$ (contact) IEC61000-4-4 (EFT) rating. 40A (5/50 us) IEC61000-4-5 (Lightning) rating. 5A (8/20 us)
- Low capacitance: 0.25pF typical
- Pb-Free, Halogen free and RoHS compliant
- Operating junction temperature $-55^{\circ}\text{C}\sim+150^{\circ}\text{C}$
- Storage temperature range $-55^{\circ}\text{C}\sim+150^{\circ}\text{C}$

Application:

- High Definition Multi-Media Interface (HDMI1.3&1.4)
- DisplayPort Interface
- SATA and eSATA Interface
- USB 2.0 and USB 3.0
- LVDS Interface
- PCI-Express

Recommended Foot Print Dimensions:

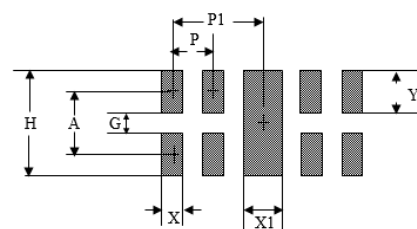

Unit	Inch	mm
Y	0.027	0.68
G	0.008	0.20
H	0.061	1.55
X	0.008	0.20
X1	0.016	0.40
P	0.020	0.50
P1	0.039	1.00
A	0.034	0.88

Shape and Dimensions:

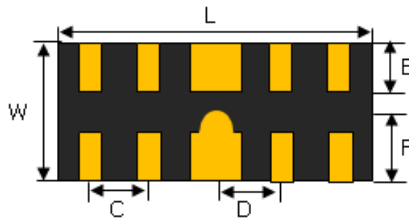

Size Inch/(mm)	L	W	C	D	E	F	H	A	B
1004 (DFN2510)	0.098 \pm 0.002 (2.5 \pm 0.05)	0.039 \pm 0.002 (1.0 \pm 0.05)	0.020 \pm 0.002 (0.5 \pm 0.05)	0.020 \pm 0.002 (0.5 \pm 0.05)	0.014 \pm 0.002 (0.35 \pm 0.05)	0.020 \pm 0.002 (0.5 \pm 0.05)	0.020 \pm 0.002 (0.5 \pm 0.05)	0.008 \pm 0.002 (0.2 \pm 0.05)	0.016 \pm 0.002 (0.4 \pm 0.05)

Circuit Symbol:

Pin	Description
1,2,4,5	Data Lines
6,7,9,10	NC
3,8	Ground

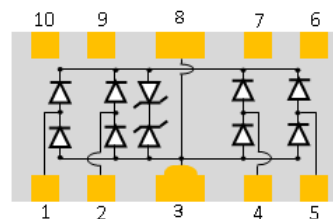

Packaging Information:

Package	Tape & Reel Quantity (piece)	Marking
1004 (DFN2510)	3,000	P424

Storage Conditions:

Storage Time: 12 months max
 Storage Temperature : 5°C to 30°C
 Relative Humidity: < 60% RH

Surface Mount TVS Diodes

ESD Protection Diode Array, TS10044C05VR25

Electrical Characteristics (@25°C):

Characteristic	Condition	Value		
		Min.	Typical	Max.
ESD per IEC61000-4-2 Direct Discharge			±12 kV	
ESD per IEC61000-4-2 Air Discharge			±17 kV	
Peak Pulse Power (P_{PK})	$t_p = 8/20\mu s$		150 W	
Maximum Peak Pulse Current (I_{PP})	$t_p = 8/20\mu s$		3.4 A	
Reverse Stand-Off Voltage (V_{RWM})				5 V
Reverse Breakdown Voltage (V_{BV})	$I_{BV} = 1mA$	6 V		
Clamping Voltage (V_{CL})	$I_{PP} = 1A, t_p = 8/20\mu s$			15 V
	$I_{PP} = 3.4A, t_p = 8/20\mu s$			25 V
Junction Capacitance (C_J)	Between I/O Pin and GND $V_{RWM} = 0V, f = 1MHz$		0.25 pF	0.4 pF
Reverse Leakage Current (I_{RM})	$V_{RWM} = 5V$			1 μA

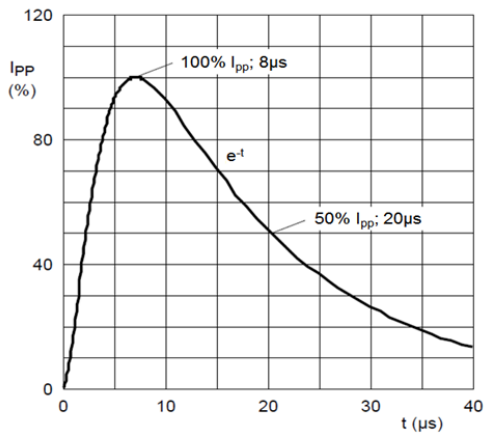

Fig. 1
8/20 μs pulse waveform according to IEC 61000-4-5

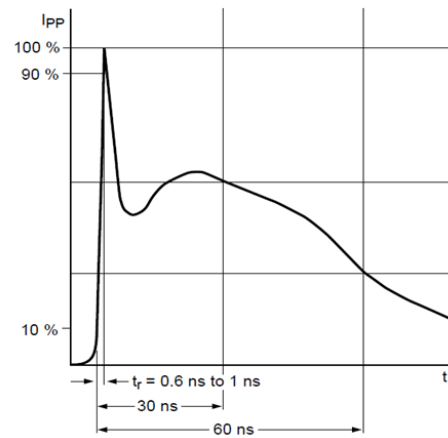

Fig. 2
ESD pulse waveform according to IEC 61000-4-2

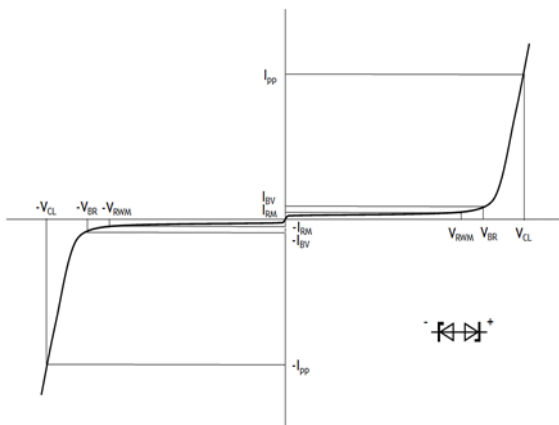

Fig. 3
V-I characteristics for bidirectional ESD protection diode

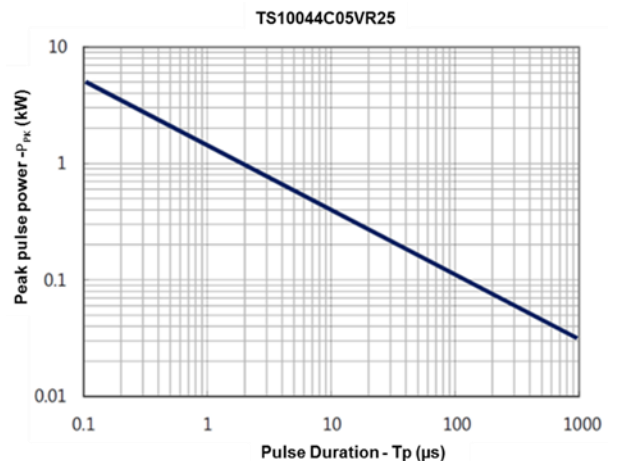

Fig. 4
Non-repetitive peak pulse power vs. Pulse time

Surface Mount TVS Diodes

ESD Protection Diode Array, TS10044C05VR25

Electrical Characteristics (@25°C):

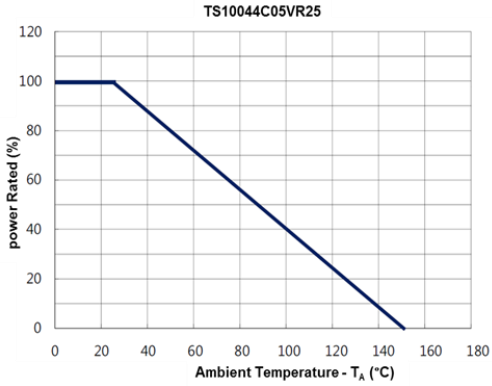

Fig. 5
Power derating vs. Ambient temperature

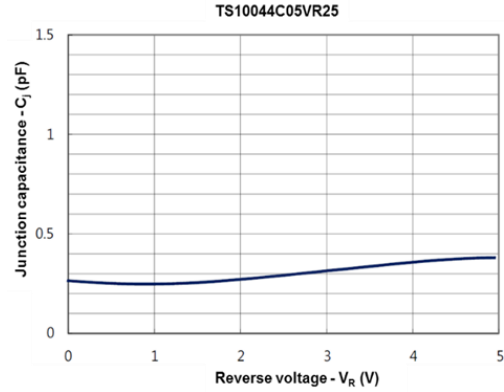

Fig. 6
Typical Junction Capacitance vs. Reverse voltage

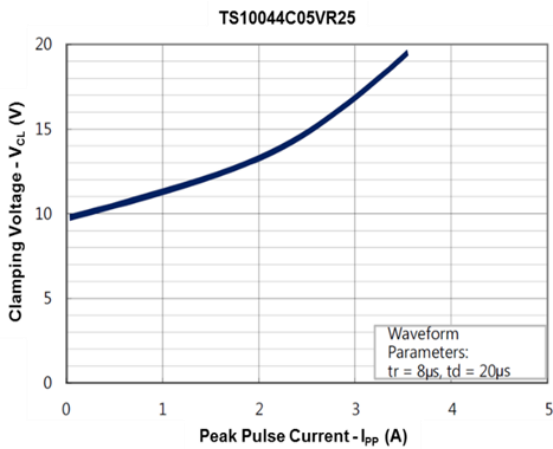

Fig. 7
Clamping voltage (V_{CL}) vs. peak pulse current (I_{PP}); $t_P = 8/20\mu s$

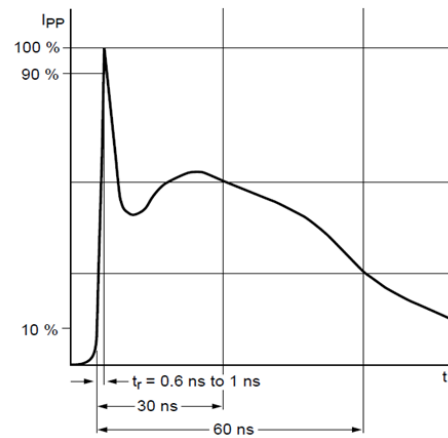

Fig. 8
Transmission Line Pulse (TLP) Measurement

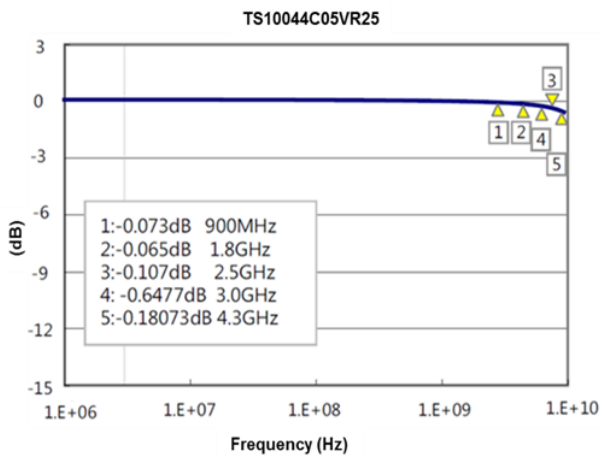

Fig. 9
Insertion Loss; Typical values

Surface Mount TVS Diodes

ESD Protection Diode Array, TS10044C05VR25

HDMI Interface Application:

HDMI Block Diagram

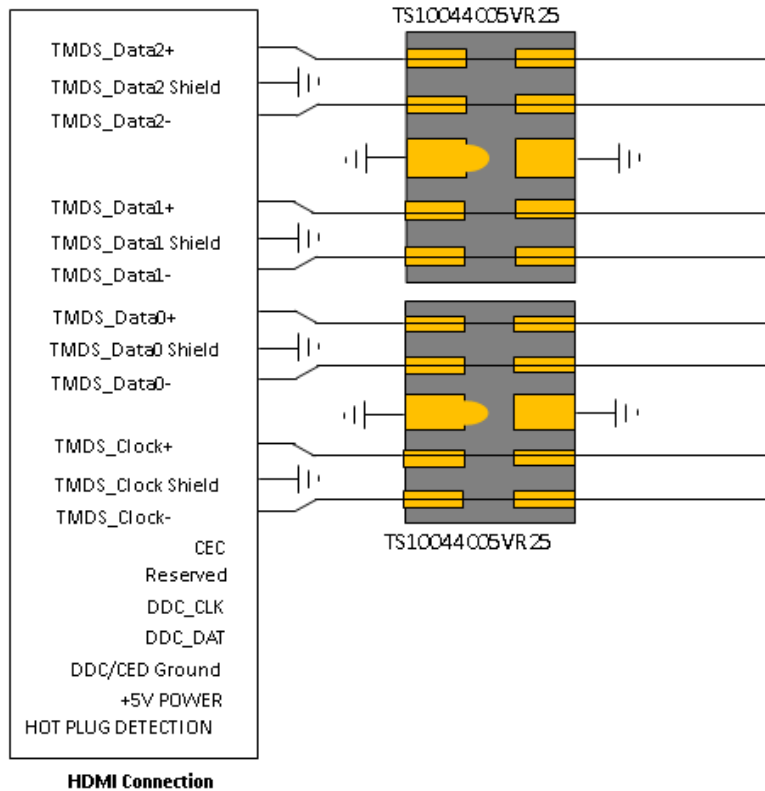
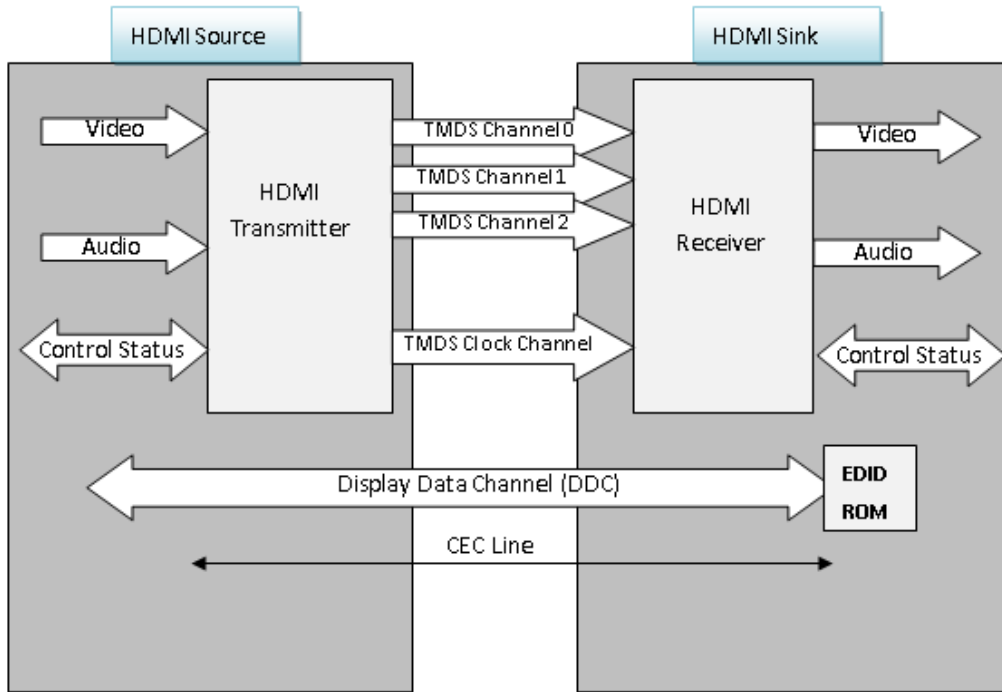

Over Voltage Protection Devices

Quick Index:

	Series	Size	Page
Surface Mount Multilayer Varistors	ES (ESD Protection)	0402, 0603, 0805	102
	NA (Normal Surge Protection)	0402, 0603, 0805, 1206, 1210, 1812, 2220	103
	HA (High Surge Protection)	1206, 1210, 1812, 2220	105
	HV (High Voltage)	3220	106
	ESD Array	0508, 0612	108
High Surge Protection Devices	SV (Super High Voltage)	1210, 1812, 2220, 3220	111
	SC (Super High Current)	1206, 1210, 1812, 2220	113
	SN (Super High Network)	1206, 1210	115

Surface Mount Multilayer Varistors

Product Identification:

MLV 0402 ES 012V 0100 N T
(1) (2) (3) (4) (5) (6) (7)

(1) Series Code:

MLV – Surface Mount Multilayer Varistor

MVA -- MLV Array

(2) Size Code:

Standard EIA Chip Size

(3) Application Code:

ES – Electro-static Discharge Protection

NA – Normal Surge Protection

HA – High Surge Protection

(4) Max. Working Voltage:

012V – 12 V

(5) Capacitance for ES Series:

0100 – 100 pF

02R5 – 2.5 pF

Peak Current for HA/NA Series: **0100** – 100 A

(6) Capacitance Tolerance for ES Series:

N – ± 30%

P – **Special**

(7) Packaging Code:

T – Tape & Reel

Operating Temperatures:

-55°C to +85°C for size 0603 or smaller

-55°C to +125°C for size 0805 or larger

Surface Mount Multilayer Varistors

Shape and Dimensions:

MLV Series

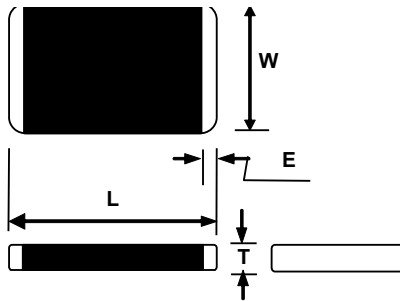

Size	L (mm)	W (mm)	T (mm)	E (mm)
0201	0.60 ± 0.03	0.30 ± 0.03	0.30 ± 0.03	0.30 ± 0.03
0402	1.00 ± 0.10	0.50 ± 0.10	0.50 ± 0.10	0.25 ± 0.10
0603	1.60 ± 0.15	0.80 ± 0.15	0.90 max.	0.30 ± 0.10
0805	2.00 ± 0.20	1.25 ± 0.15	1.00 max.	0.30 ± 0.10
1206	3.20 ± 0.20	1.60 ± 0.15	1.20 max.	0.50 ± 0.20
1210	3.20 ± 0.20	2.50 ± 0.20	1.50 max.	0.50 ± 0.20
1812	4.50 ± 0.20	3.20 ± 0.20	2.00 max.	0.60 ± 0.20
2220	5.70 ± 0.20	5.00 ± 0.20	3.00 max.	0.60 ± 0.20

ESD Array

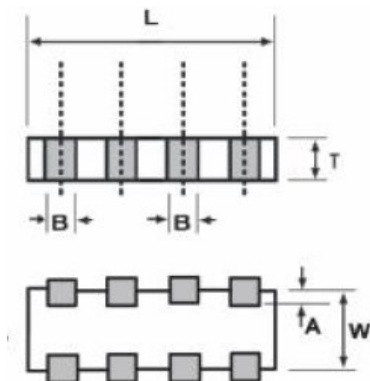

Size	0508	0612
L (mm)	2.00 ± 0.20	3.20 ± 0.20
W (mm)	1.25 ± 0.20	1.60 ± 0.15
T (mm)	0.80 max.	0.95 max.
A (mm)	0.20 ± 0.10	0.20 ± 0.10
B (mm)	0.25 ± 0.05	0.40 ± 0.15

Terms and Definitions:

Term	Definition
Max. Working Voltage	Maximum steady-state DC operating voltage with typical leakage current less than 50 μ A at 25°C
Varistor Voltage (BDV)	Breakdown DC voltage measured at current of 1 mA
Max. Clamping Voltage	Maximum peak voltage across the part, measured at a specified pulse current and waveform
Surge Current	Maximum peak current with the specified 8/20 μ s waveform without damage
Surge Shift $\Delta V/V$	The change of varistor voltage after applying the specified surge current
Energy Absorption	Maximum energy dissipated with a specified 10/1000 μ s waveform without damage
Typical Capacitance	Capacitance measured with voltage bias less than 0.5 V_{RMS} at 1 KHz or 1 MHz
Nonlinear Exponent α	$\alpha = (\log(V_{1mA}/V_{0.1mA}) / \log(I_{V1mA}/I_{V0.1mA}))$
Leakage Current	Typical leakage current at 25 °C < 50 μ A; Maximum leakage 200 μ A.
Cut-off Frequency	The frequency of -3 dB insertion loss

Surface Mount Multilayer Varistors

Recommended Land Patterns:

MLV Series

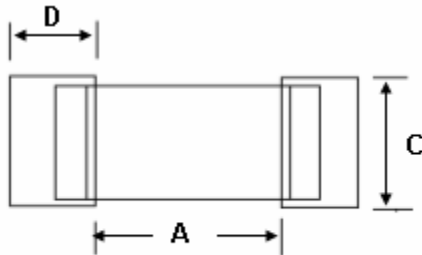

Size	Solder pad layout		
	A (mm)	C (mm)	D (mm)
0201	0.25~0.35	0.20~0.30	0.25~0.35
0402	0.4~0.6	0.5~0.6	0.5~0.7
0603	0.9~1.2	0.6~1.0	0.8~1.2
0805	1.0~1.5	1.2~1.5	1.0~1.4
1206	1.8~2.5	1.2~1.8	1.0~1.4
1210	1.8~2.5	2.2~3.0	1.0~1.4
1812	2.5~3.3	2.8~3.6	1.2~1.8
2220	3.8~4.6	4.8~5.5	1.2~1.8

ESD Array Series

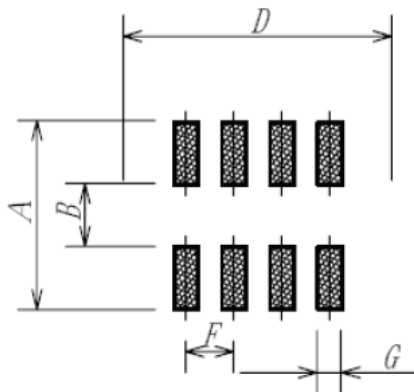

Size	A (mm)	B (mm)	D (mm)	F (mm)	G (mm)
0508	2.10	0.40	2.50	0.50	0.35
0612	2.60	0.80	3.60	0.80	0.50

Surface Mount Multilayer Varistors

Environmental Tests:

No.	Test	Requirement	Test condition	Test reference
1	Soldering heat resistance	BDV change $\leq \pm 10\%$ No mechanical damage	One dip at 260°C for 5 sec.	MIL-STD-202 Method 210 IEC 60068-2-20
2	Solderability	New solder coverage $\geq 80\%$	One dip at 255°C for 5 sec. Non-active flux	MIL-STD-202 Method 208 IEC 60068-2-20
3	Maximum surge current	BDV change $\leq \pm 10\%$ No mechanical damage	100 pulses of 8/20 μs with maximum surge current and 30 sec. interval at 25°C and 30 ~ 65% RH	CECC 42000 IEC 1051-1 Test 4.5
4	Maximum surge energy	BDV change $\leq \pm 10\%$ No mechanical damage	100 pulses of 10/1000 μs with maximum surge current and 90 sec. interval at 25°C and 30 ~ 65% RH	CECC 42000
5	Thermal cycling	BDV change $\leq \pm 10\%$ No mechanical damage Leakage current $\leq 200 \mu\text{A}$	5 cycles between -40°C and 125°C with 30 min. dwell time at the temperature extremes and 60 min. dwell time at 25°C	CECC 42000 IEC 60068-2-14
6	Low temperature resistance	BDV change $\leq \pm 10\%$ No mechanical damage Leakage current $\leq 200 \mu\text{A}$	1000 hr at -50°C	IEC 60068-2-1
7	Low temperature load resistance	BDV change $\leq \pm 10\%$ No mechanical damage Leakage current $\leq 200 \mu\text{A}$	1000 hr at -50°C with working voltage applied	IEC 60068-2-1
8	High temperature resistance	BDV change $\leq \pm 10\%$ No mechanical damage Leakage current $\leq 200 \mu\text{A}$	1000 hr at 150°C	MIL-STD-202 Method 108 CECC 42000
9	High temperature load resistance	BDV change $\leq \pm 10\%$ No mechanical damage Leakage current $\leq 200 \mu\text{A}$	1000 hr at 85°C with working voltage applied	CECC 42000
10	Humidity resistance	BDV change $\leq \pm 10\%$ No mechanical damage Leakage current $\leq 200 \mu\text{A}$	500 hr at 40°C and 90 ~ 95% RH	MIL-STD-202 Method 103 IEC 60068-2-3 CECC 42000;
11	Humidity load resistance	BDV change $\leq \pm 10\%$ No mechanical damage Leakage current $\leq 200 \mu\text{A}$	500 hr at 40°C and 90 ~ 95% RH with working voltage applied	MIL-STD-202 Method 103 IEC 60068-2-3 CECC 42000
12	ESD contact test*	Varistor voltage change > 115% working voltage	Contact electrostatic discharge 100 times with 1 second intervals at 8 KV (Level 4) and polarity: +,-	IEC 61000-4-2
13	ESD air test*	Varistor voltage change > 115% working voltage	Air contact electrostatic discharge 100 times with 1 second intervals at 15 KV (Level 4) and polarity: +,-	IEC 61000-4-2

* For ES series only.

Surface Mount Multilayer Varistors

Soldering Temperature Profile:

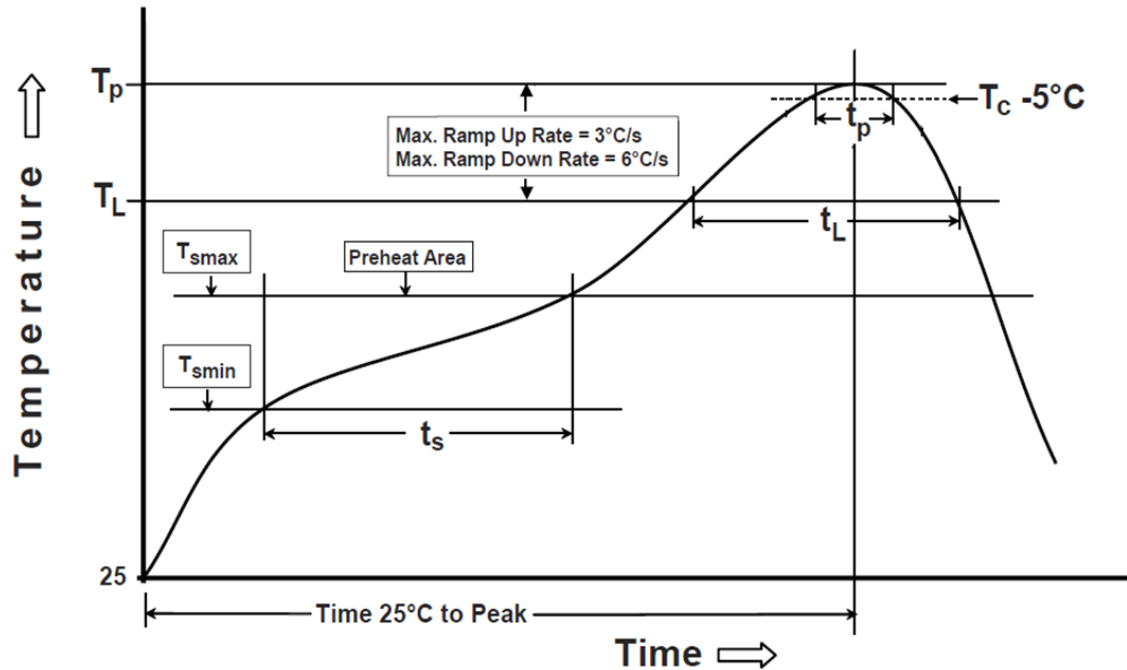

Profile Feature	Pb-Free Assembly
Preheat/Soak Temperature Min (T_{smin}) Temperature Max (T_{smax}) Time (t_s) from (T_{smin} to T_{smax})	150°C 200°C 60~120 seconds
Ramp-uprate (T_L to T_p)	3°C/second max.
Liquidous temperature (T_L) Time (t_L) maintained above T_L	217°C 60~150 seconds
Peak package body temperature (T_p)	260°C
Time (t_p)*within 5°C of the specified classification temperature (T_c)	30 seconds *
Ramp-down rate (T_p to T_L)	6°C/second max.
Time 25°C to peak temperature	8 minutes max.
* Tolerance for peak profile temperature (T_p) is defined as a supplier minimum and a user maximum	

Surface Mount Multilayer Varistors

ESD Protection (ES) Series

Features:

- Fast Response < 0.5 ns
- Low Working Voltage 5 V
- Low Capacitance
- Low Leakage Current < 1 μ A
- Low Clamping Voltage

Application Fields:

- Cell Phones
- Digital Cameras
- PDAs
- MP3
- Notebooks

Part Number	Working Voltage (Max)	Clamping Voltage (Max)	Leakage Current (Max)	Typical Capacitance Value (1 MHz)	Tolerance of Cap.
	DC(V)	(V)	ILDC(μ A)	C (pF)	(%)
MLV0402ES005V0100N	5.5	55	1	100	\pm 30
MLV0402ES005V0056N	5.5	55	1	56	\pm 30
MLV0402ES005V0033N	5.5	55	1	33	\pm 30
MLV0402ES005V0022N	5.5	55	1	22	\pm 30
MLV0402ES005V0010N	5.5	60	1	10	\pm 30
MLV0402ES005V0005P	5.5	76	1	5	5~9 pF
MLV0402ES012V0100N	12	55	1	100	\pm 30
MLV0402ES012V0056N	12	55	1	56	\pm 30
MLV0402ES012V0033N	12	55	1	33	\pm 30
MLV0402ES012V0022N	12	55	1	22	\pm 30
MLV0402ES012V0010N	12	60	1	10	\pm 30
MLV0402ES012V0005P	12	80	1	5	5~9 pF
MLV0402ES024V0003N	24	120	1	3	\pm 30
MLV0402ES024V02R5P	24	198	1	2.5	2~4 pF
MLV0402ES024V00R8P	24	200	1	0.8	0.8~1.5 pF
MLV0603ES005V0100N	5.5	55	1	100	\pm 30
MLV0603ES005V0056N	5.5	55	1	56	\pm 30
MLV0603ES005V0033N	5.5	55	1	33	\pm 30
MLV0603ES005V0022N	5.5	55	1	22	\pm 30
MLV0603ES005V0010N	5.5	60	1	10	\pm 30
MLV0603ES005V0005P	5.5	76	1	5	5~9 pF
MLV0603ES012V0100N	12	55	1	100	\pm 30
MLV0603ES012V0056N	12	55	1	56	\pm 30
MLV0603ES012V0033N	12	55	1	33	\pm 30
MLV0603ES012V0022N	12	55	1	22	\pm 30
MLV0603ES012V0010N	12	60	1	10	\pm 30
MLV0603ES012V0005P	12	80	1	5	5~9 pF
MLV0603ES024V0003N	24	120	1	3	\pm 30
MLV0603ES024V02R5P	24	198	1	2.5	2~4 pF
MLV0603ES024V00R8P	24	200	1	0.8	0.8~1.5 pF
MLV0805ES005V0100N	5.5	50	1	100	\pm 30
MLV0805ES005V0056N	5.5	50	1	56	\pm 30

Surface Mount Multilayer Varistors

Normal Surge Protection (NA) Series

Features:

- Fast Response < 0.5 ns
- Low Capacitance
- Low Clamping Voltage and High Energy Absorption

Application Fields:

- Telecommunications
- Automotive Systems
- Data Systems
- Power Supplies

Ordering Information:

Part Number	Working Voltage (max)		Breakdown Voltage 1 mA (V)	Peak Current (max) 8/20 μ s (A)	Clamping Voltage (max)		Energy Absorption (max) 10/1000 μ s (J)	Typical Capacitance Ref. 1 KHz (pF)
	AC (V _{RMS})	DC (V)			(A)	(V)		
MLV0402NA006V0020	4	5.5	8 (7.5~10.5)	20	1	20	0.05	200
MLV0402NA009V0020	6	9	12 (10.2~13.8)	20	1	23	0.05	135
MLV0402NA011V0020	8	11	15 (12.8~17.3)	20	1	25	0.05	75
MLV0402NA014V0020	11	14	18 (15.3~20.7)	20	1	30	0.05	50
MLV0402NA018V0020	14	18	24 (21.6~26.4)	20	1	39	0.05	45
MLV0603NA006V0030	4	5.5	8 (7.5~10.5)	30	1	20	0.1	360
MLV0603NA009V0030	6	9	12 (10.2~13.8)	30	1	23	0.1	300
MLV0603NA014V0030	11	14	18 (15.3~20.7)	30	1	30	0.1	210
MLV0603NA018V0030	14	18	24 (21.6~26.4)	30	1	39	0.1	160
MLV0603NA022V0030	17	22	27 (24.3~29.7)	30	1	44	0.1	145
MLV0603NA030V0030	25	30	39 (35.1~42.9)	30	1	65	0.1	110
MLV0603NA038V0030	30	38	47 (42.3~51.7)	30	1	77	0.1	90
MLV0805NA006V0080	4	5.5	8 (7.5~10.5)	80	1	20	0.1	1400
MLV0805NA009V0080	6	9	12 (10.2~13.8)	80	1	23	0.1	650
MLV0805NA011V0100	8	11	15 (12.75~17.25)	100	1	25	0.2	410
MLV0805NA014V0100	11	14	18 (15.3~20.7)	100	1	30	0.2	350
MLV0805NA018V0100	14	18	24 (21.6~26.4)	100	1	39	0.2	300
MLV0805NA022V0100	17	22	27 (24.3~29.7)	100	1	44	0.2	250
MLV0805NA026V0100	20	26	33 (29.7~36.3)	100	1	54	0.3	220
MLV0805NA030V0100	25	30	39 (35.1~42.9)	100	1	65	0.3	200
MLV0805NA038V0100	30	38	47 (42.3~51.7)	100	1	77	0.3	150
MLV0805NA045V0080	35	45	56 (50.4~61.6)	80	1	90	0.3	110
MLV1206NA006V0100	4	5.5	8 (7.5~10.5)	100	1	20	0.2	3100
MLV1206NA014V0100	11	14	18 (15.3~20.7)	100	1	30	0.3	800
MLV1206NA018V0100	14	18	24 (21.6~26.4)	100	1	38	0.3	620
MLV1206NA022V0100	17	22	27 (24.3~29.7)	100	1	44	0.4	700
MLV1206NA026V0100	20	26	33 (29.7~36.3)	100	1	54	0.5	480
MLV1206NA030V0100	25	30	39 (35.1~42.9)	100	1	65	0.6	400

Surface Mount Multilayer Varistors

Normal Surge Protection (NA) Series

Ordering Information:

Part Number	Working Voltage (max)		Breakdown Voltage 1 mA (V)	Peak Current (max) 8/20 μ s (A)	Clamping Voltage (max)		Energy Absorption (max) 10/1000 μ s (J)	Typical Capacitance 1 KHz (pF)
	AC (V _{RMS})	DC (V)			(A)	(V)		
MLV1206NA038V0100	30	38	47 (42.3~51.7)	100	1	77	0.7	260
MLV1206NA045V0100	35	45	56 (50.4~61.6)	100	1	90	0.8	230
MLV1206NA056V0100	40	56	68 (61.2~74.8)	100	1	110	1.0	200
MLV1206NA065V0100	50	65	82 (73.8~90.2)	100	1	135	0.5	175
MLV1206NA085V0100	60	85	100 (90~110)	100	1	165	0.6	150
MLV1210NA006V0250	4.5	5.5	8 (7.5~10.5)	250	2.5	20	0.5	5200
MLV1210NA018V0250	14	18	24 (21.6~26.4)	250	2.5	38	0.8	1150
MLV1210NA022V0250	17	22	27 (24.3~29.7)	250	2.5	44	1.0	1720
MLV1210NA026V0250	20	26	33 (29.7~36.3)	250	2.5	54	1.2	610
MLV1210NA030V0250	25	30	39 (35.1~42.9)	250	2.5	65	1.4	920
MLV1210NA038V0250	30	38	47 (42.3~51.7)	250	2.5	77	1.6	780
MLV1210NA045V0250	35	45	56 (50.4~61.6)	250	2.5	90	2.0	400
MLV1210NA056V0250	40	56	68 (61.2~74.8)	250	2.5	110	2.3	300
MLV1210NA085V0200	60	85	100 (90~110)	200	2.5	165	1.4	210
MLV1812NA018V0500	14	18	24 (21.6~26.4)	500	5	38	1.7	2000
MLV1812NA030V0500	25	30	39 (35.1~42.9)	500	5	65	2.9	2500
MLV1812NA038V0500	30	38	47 (42.3~51.7)	500	5	77	3.5	2200
MLV1812NA045V0500	35	45	56 (50.4~61.6)	500	5	90	4.2	1000
MLV2220NA018V1000	14	18	24 (21.6~26.4)	1000	10	38	3.1	8500
MLV2220NA030V1000	25	30	39 (35.1~42.9)	1000	10	65	5.5	3900
MLV2220NA038V1000	30	38	47 (42.3~51.7)	1000	10	77	6.3	4600
MLV2220NA056V1000	40	56	68 (61.2~74.8)	1000	10	110	8.8	4000

Surface Mount Multilayer Varistors

High Surge Protection (HA) Series

Features:

- Fast Response < 0.5 ns
- Low Capacitance
- Low Clamping Voltage and High Energy Absorption

Application Fields:

- Telecommunications
- Automotive Systems
- Data Systems
- Power Supplies

Ordering Information:

Part Number	Working Voltage (max)		Breakdown Voltage 1 mA (V)	Peak Current (max) 8/20 μ s (A)	Clamping Voltage (max)		Energy Absorption (max) 10/1000 μ s (J)	Typical Capacitance 1 KHz (pF)
	AC (V _{RMS})	DC (V)			(A)	(V)		
MLV1206HA014V0200	11	14	18 (15.3~20.7)	200	1	30	0.5	1200
MLV1206HA018V0200	14	18	24 (21.6~27.0)	200	1	39	0.5	780
MLV1206HA022V0200	17	22	27 (24.3~29.8)	200	1	44	0.7	750
MLV1206HA026V0200	20	26	33 (29.7~36.3)	200	1	54	1.0	700
MLV1206HA030V0200	25	30	39 (35.1~42.9)	200	1	65	1.0	510
MLV1206HA038V0200	30	38	47 (42.3~51.7)	200	1	77	1.1	440
MLV1210HA014V0400	11	14	18 (15.3~20.7)	400	2.5	30	1.2	2000
MLV1210HA018V0400	14	18	24 (21.6~27.0)	400	2.5	39	1.4	1600
MLV1210HA022V0400	17	22	27 (24.3~29.8)	400	2.5	44	1.7	1500
MLV1210HA026V0400	20	26	33 (29.7~36.3)	400	2.5	54	1.9	880
MLV1210HA030V0400	25	30	39 (35.1~42.9)	400	2.5	65	1.7	800
MLV1210HA038V0400	30	38	47 (42.3~51.7)	400	2.5	77	2.0	530
MLV1812HA018V0800	14	18	24 (21.6~27.0)	800	5	38	2.3	3500
MLV1812HA030V0800	25	30	39 (35.1~42.9)	800	5	65	3.7	2350
MLV1812HA038V0800	30	38	47 (42.3~51.7)	800	5	77	4.2	1600
MLV1812HA045V0800	35	45	56 (50.4~61.6)	800	5	90	4.2	1200
MLV2220HA014V1200	11	14	18 (15.3~20.7)	1200	10	30	5.4	10500
MLV2220HA018V1200	14	18	24 (21.6~27.0)	1200	10	39	5.8	8500
MLV2220HA022V1200	17	22	27 (24.3~29.8)	1200	10	44	7.2	8300
MLV2220HA030V1200	25	30	39 (35.1~42.9)	1200	10	65	9.6	6000
MLV2220HA038V1200	30	38	47 (42.3~51.7)	1200	10	77	12.0	4000
MLV2220HA045V1200	35	45	56 (50.4~61.6)	1200	10	90	12.0	3500

Surface Mount Multilayer Varistors

High Voltage (HV) Series

Features:

- Bidirectional and symmetrical V/I characteristics Low Capacitance
- Meet IEC61000-4-2 Standard
- Large withstanding surge current capability - 400~500A (@8/20 μ s)
- Multilayer construction provides higher power dissipation

Shape and Dimensions:

Unit (mm)	Length (L)	Width (W)	Thickness (T)	Termination bandwidth (b)
MLV3220HV240V0500	8.1 \pm 0.30	5.0 \pm 0.30	1.7 \pm 0.30	0.8 +0.5/-0.1
MLV3220HV270V0500				
MLV3220HV390V0500				
MLV3220HV430V0450				
MLV3220HV470V0400				

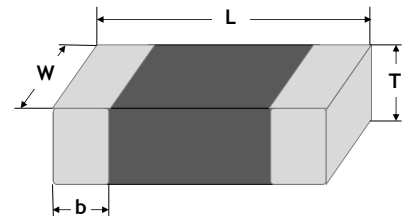

Product Identification:

MLV	3220	HV	270V	0500
<u>Category Code</u>	<u>Size Code</u>	<u>Application Code</u>	<u>Breakdown Voltage Code</u>	<u>Surge Current Code</u>
MLV = Multilayer Varistor	Inch (mm) 3220 (8153)	HV = High Voltage	390V = 390V 430V = 430V 470V = 470V	0400 = 400A 0450 = 450A 0500 = 500A

Electrical Characteristics:

Operating temperature: -55 to +85°C

Part Number	Size	Working Voltage		Breakdown Voltage ¹ @1mA (V)	Clamping Voltage ²		Surge Current ³ @8/20 μ s (A)	Energy (J)	Capacitance ⁴ @1kHz (pF)
		Vac	Vdc		A	V			
MLV3220HV240V0500	3220	150	200	240 (\pm 10%)	10	390	500	> 14.5	380
MLV3220HV270V0500		175	225	270 (\pm 10%)		450	500	> 16.0	340
MLV3220HV390V0500		250	330	390 (\pm 10%)		647	500	> 20.0	125
MLV3220HV430V0450		275	369	430 (\pm 10%)		705	450	> 21.0	120
MLV3220HV470V0400		300	385	470 (\pm 10%)		775	400	> 21.6	115

¹ The breakdown voltage was measured at 1 mA current.

² The clamping voltage was measured at standard current 3220 (10A).

³ The surge current was tested at 8/20 μ s waveform.

⁴ The capacitance value only for customer reference, it's not formal specification.

Surface Mount Multilayer Varistors

High Voltage (HV) Series

Construction and Materials:

Body ①	Termination ②
ZnO	Ag/Ni/Sn

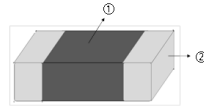

Packaging:

Chip Size	Parts on 7 inch (178mm) Reel
3220	1,000

Recommended Foot Print Dimensions:

Size	A (mm)	B (mm)	C (mm)
3220	6.2~7.0	1.6~2.6	4.8~5.8

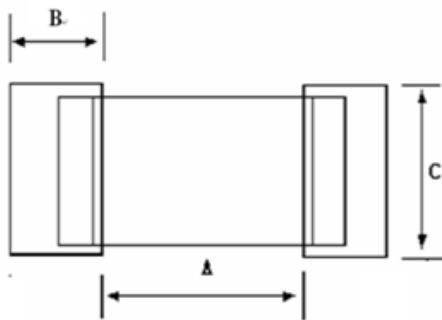

Surge Waveform:

Severity Level	t1 (=1.67t'1)	t2
1	8 μs	20 μs

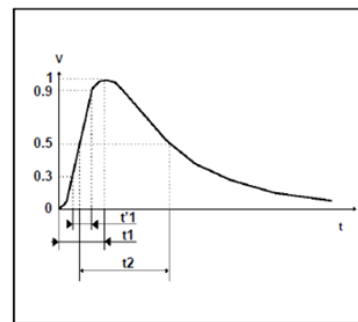

Environmental Test:

Test item	Test condition	Requirement
High Temperature Storage	* Temperature : 125±2°C * Time : 1000±2 hours * Test after placing in ambient temperature for 24 hours	* Breakdown voltage change : within ±10% * No mechanical damage
High Temperature Storage	* Temperature : 125±2°C * Time : 1000±2 hours * Test after placing in ambient temperature for 24 hours	* Breakdown voltage change : within ±10% * No mechanical damage
High Temperature Storage	* Temperature : 125±2°C * Time : 1000±2 hours * Test after placing in ambient temperature for 24 hours	* Breakdown voltage change : within ±10% * No mechanical damage
High Temperature Load	* Temperature : 85±2°C * Rated working voltage applied * Time : 1000±2 hours * Test after placing in ambient temperature for 24 hours	* Breakdown voltage change : within ±10% * No mechanical damage
High Temperature Load	* Temperature : 85±2°C * Rated working voltage applied * Time : 1000±2 hours * Test after placing in ambient temperature for 24 hours	* Breakdown voltage change : within ±10% * No mechanical damage

Surface Mount Multilayer Varistors

ESD Array Series

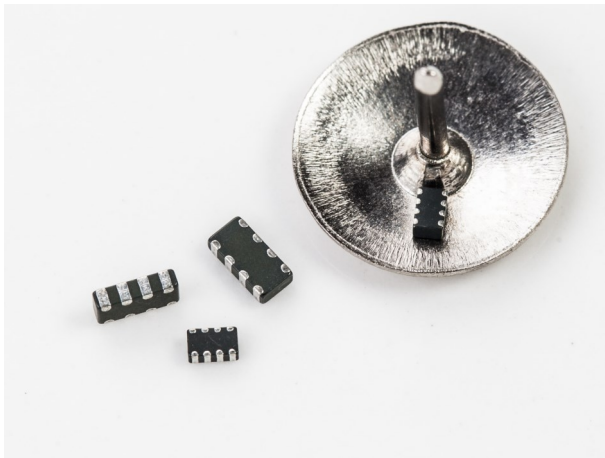

Features:

- Low Leakage Current
- Low Leakage Inductance and Fast Response
- Four Varistors in a chip
- Minimizing Crosstalk between Adjacent Circuits

Application Fields:

- ESD protection
- ECU protection
- I/O Protection
- LCD Display

Ordering Information:

Part Number	Working Voltage (Max.)	Breakdown Voltage	Clamping Voltage (Max.)	Leakage Current (Max.)	Insulation Resistance (Min.)	Typical Capacitance Value (1 MHz)	Tolerance of Cap.
	DC(V)	(V)	(V)	(μ A)	(M Ω)	(pF)	(%)
MVA0508L4V005C0010N	5	24	60	1.0	10	10	\pm 30
MVA0612L4V018C0120N	18	28	50	1.0	10	120	\pm 30

High Surge Protection Devices

Construction and Materials:

Body ①	Termination ②
Nano special ceramic	Ag/Ni/Sn

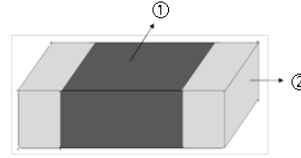

Packaging:

Chip Size	Parts on 7 inch (178mm) Reel
0806	2,000
1206	2,000
1210	1,500
1812	500
2220	500
3220	500

Environmental Test:

Test item	Test condition	Requirement
High Temperature Storage	*Temperature : 125±2°C * Time : 1000±2 hours *Test after placing in ambient temperature for 24 hours	* Breakdown voltage change : within ±10% * No mechanical damage
Low Temperature Storage	*Temperature : -40±2°C * Time : 1000±2 hours *Test after placing in ambient temperature for 24 hours	* Breakdown voltage change : within ±10% * No mechanical damage
Temperature Cycle	* Step 1 : -40±3°C for 30±3min * Step 2 : 25°C for 1 hour * Step 3 : 125±3°C for 30±3min * Step 4 : 25°C for 1 hour * Number of cycle : 5 times *Test after placing in ambient temperature for 24 hours	* Breakdown voltage change : within ±10% * No mechanical damage
High Temperature Load	*Temperature : 85±2°C * Rated working voltage applied * Time : 1000±2 hours *Test after placing in ambient temperature for 24 hours	* Breakdown voltage change : within ±10% * No mechanical damage
Damp Heat Load/Humidity Load	*Temperature : 40±2°C * Humidity : 90~95% RH * Rated working voltage applied * Time : 500±2 hours *Test after placing in ambient temperature for 24 hours	* Breakdown voltage change : within ±10% * No mechanical damage

High Surge Protection Devices

Recommended Foot Print Dimensions:

Size	A (mm)	B (mm)	C (mm)
0806	1.2~1.6	0.8~1.2	1.6~2.2
1206	1.8~2.5	1.2~1.8	1.5~2.0
1210	1.8~2.5	1.3~2.0	2.2~3.0
1812	2.5~2.9	1.6~2.0	3.2~3.6
2220	3.8~4.6	1.3~2.2	4.8~5.5
3220	6.2~7.0	1.6~2.6	4.8~5.8

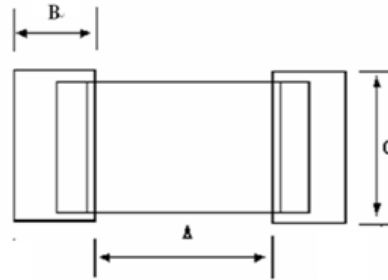

Recommended Reflow Soldering Profile:

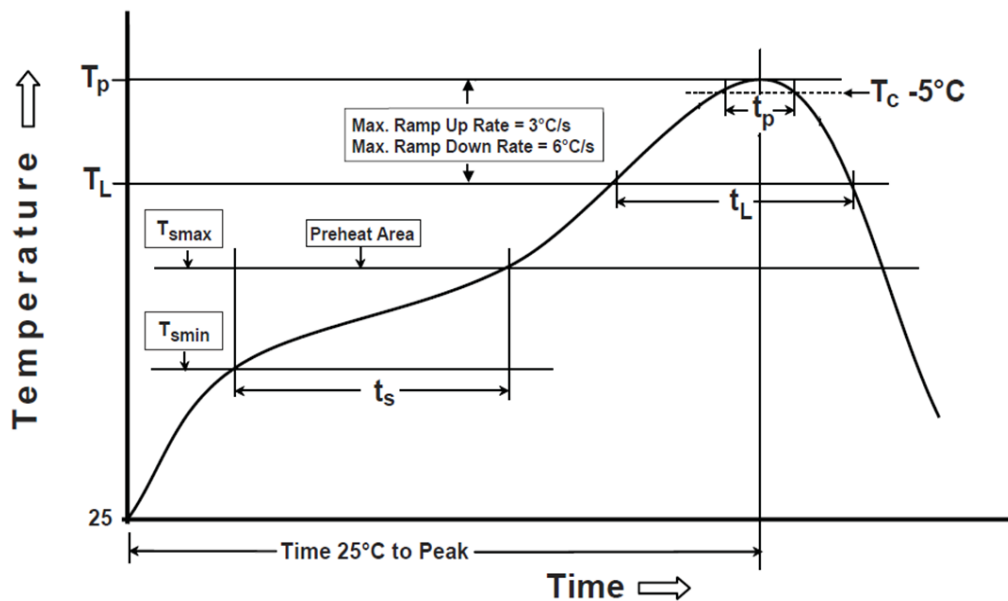

Profile Feature	Pb-Free Assembly
Preheat/Soak Temperature Min (T_{smin}) Temperature Max (T_{smax}) Time (t_s) from (T_{smin} to T_{smax})	150°C 200°C 60~120 seconds
Ramp-up rate (T_L to T_p)	3°C/second max.
Liquidous temperature (T_L) Time (t_L) maintained above T_L	217°C 60~150 seconds
Peak package body temperature (T_p)	260°C
Time (t_p)*within 5°C of the specified classification temperature (T_c)	30 seconds *
Ramp-down rate (T_p to T_L)	6°C/second max.
Time 25°C to peak temperature	8 minutes max.
* Tolerance for peak profile temperature (T_p) is defined as a supplier minimum and a user maximum	

High Surge Protection Devices Super High Voltage (SV) Series

Features:

- SMD type body size 0806, 1206, 1208, 1210, 1812, 2220 and 3220
- Bidirectional and symmetrical V/I characteristics
- Meet IEC61000-4-5 Standard
- Large withstanding surge voltage capability - 0.5~2KV (@1.2/50 μ s, 2 Ω)
- Large withstanding surge current capability - 100~1000A (@8/20 μ s)
- Multilayer construction provides higher power dissipation
- RoHS compliant

Application Fields:

- LED lighting
- Power board
- Base station
- AC power supply
- Industrial equipment and controllers

Application Fields:

Recognized under the components program of UL and CSA

Shape and Dimensions:

Unit (mm)	0806	1206	1210	1812	2220	3220
Length (L)	2.20 \pm 0.20	3.20+0.60/-0.20	3.20+0.60/-0.20	4.50+0.60/-0.20	6.00+0.70/-0.30	8.10+0.70/-0.30
Width (W)	1.70 \pm 0.20	1.60+0.40/-0.20	2.50+0.40/-0.20	3.20+0.50/-0.20	5.30+0.50/-0.30	5.30+0.60/-0.30
Thickness (T)	1.80 Max.	1.90 Max.	2.60 Max.	3.50 Max.	3.60 Max.	3.70 Max.
Termination bandwidth (b)	0.25 \pm 0.10	0.50 \pm 0.20	0.50 \pm 0.25	0.50+0.35/-0.10	0.50+0.35/-0.10	0.80+0.50/-0.10

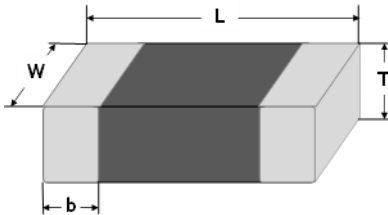

Product Identification:

HSP	2220	SV	390V	0800
<u>Category Code</u>	<u>Size Code</u>	<u>Application Code</u>	<u>Breakdown Voltage Code</u>	<u>Surge Current Code</u>
HSP = High Surge Protection Device	Inch 0806 1206 1210 1812 2220 3220	SV = Super High Voltage	240V = 240V 270V = 270V 390V = 390V 430V = 430V 470V = 470V	0100 = 100A 0200 = 200A 0350 = 350A 0500 = 500A 0800 = 800A 1000 = 1000A

High Surge Protection Devices

Super High Voltage (SV) Series

Electrical Characteristics:

Operating temperature: -55 to +85°C

Part Number	Size	Working Voltage		Breakdown Voltage ¹ @1mA (V)	Clamping Voltage ² (V)	Surge Voltage ³ @1.2/50µs, 2Ω (kV)		Surge Current ³ @8/20µs (A)		Energy Max. @10/1000 µs (J)	Capacitance ⁴ @1kHz (pF)	Safety Certification	
		Vac	Vdc			1 time	15 times	1 time	15 times			UL ⁵	CSA ⁶
HSP0806SV240V0200	0806	150	200	240 (±10%)	395	0.5	200	100	4.4	95	Pending		
HSP0806SV430V0100	0806	275	350	430 (±10%)	705	0.5	100	100	4.3	45	Pending		
HSP1206SV240V0350	1206	150	200	240 (±10%)	395	0.5	350	200	7.7	180	Pending		
HSP1210SV390V0200	1210	250	320	390 (±10%)	647	0.5	200	100	7.2	105	✓		
HSP1210SV470V0250	1210	300	385	470 (±10%)	775	0.5	250	150	11.9	100	Pending		
HSP1210SV470V0500	1210	300	385	470 (±10%)	775	1.0	500	250	23.8	190	Pending		
HSP1812SV270V0500	1812	175	225	270 (±10%)	450	1.0	500	250	22.0	275	✓		
HSP1812SV470V0500	1812	300	385	470 (±10%)	775	1.0	500	250	23.0	200	✓	✓	
HSP1812SV430V0800	1812	275	350	430 (±10%)	705	2.0	800	500	38.0	340	✓	✓	
HSP1812SV470V0800	1812	300	385	470 (±10%)	775	2.0	800	500	38.0	310	✓	✓	
HSP2220SV270V0500	2220	175	225	270 (±10%)	450	1.0	500	250	13.8	390	Pending		
HSP2220SV390V0500	2220	250	320	390 (±10%)	647	1.0	500	250	19.8	235	✓		
HSP2220SV430V0500	2220	275	350	430 (±10%)	705	1.0	500	250	21.6	215	✓		
HSP2220SV470V0500	2220	300	385	470 (±10%)	775	1.0	500	250	23.7	195	✓		
HSP2220SV240V0800	2220	139	195	240 (±10%)	295	2.0	800	500	21.0	430	Pending		
HSP2220SV390V0800	2220	250	320	390 (±10%)	647	2.0	800	500	31.8	320	✓		
HSP2220SV430V0800	2220	275	350	430 (±10%)	705	2.0	800	500	34.7	305	✓	✓	
HSP2220SV470V0800	2220	300	385	470 (±10%)	775	2.0	800	500	38.0	290	✓	✓	
HSP3220SV430V1000	3220	275	350	430 (±10%)	705	2.0	1000	500	46.8	490	Pending		
HSP3220SV470V1000	3220	300	385	470 (±10%)	775	2.0	1000	500	51.5	450	Pending		

¹ The breakdown voltage was measured at 1 mA current.

² The clamping voltage was measured at standard current 1210 (2.5A), 1812 (5A), 2220 (10A) and 3220 (10A).

³ The surge voltage was tested at 1.2/50 µs waveform and 2Ω. The surge current was tested at 8/20 µs waveform.

⁴ The capacitance value only for customer reference, it's not formal specification.

⁵ The UL safety approval complies with standard UL1449 3rd.

⁶ The CSA safety approval complies with standard CSA C22.2 No. 8.

High Surge Protection Devices Super High Current (SC) Series

Features:

- SMD type – 1206~2220 sizes
- Bidirectional and symmetrical V/I characteristics
- Meet IEC61000-4-5/K21 standard
- Large withstanding surge current capability à 500~8000A (@8/20µs)
- Excellent low leakage current <math><15\mu\text{A}</math>
- Multilayer construction provides higher power dissipation
- RoHS compliant

Application Fields:

- Telecom equipment RJ45, LAN connector, Ethernet
- Outdoor/Indoor AP/IAD
- Security system IP CAM
- Low voltage power line
- Base station

Shape and Dimensions:

Unit (mm)	1206	1210	1812	2220
Length (L)	3.2 +0.6/-0.2	3.2 +0.6/-0.2	4.5 +0.6/-0.2	6.0 +0.7/-0.3
Width (W)	1.6 +0.4/-0.2	2.5 +0.4/-0.2	3.2 +0.5/-0.2	5.3 +0.5/-0.3
Thickness (T)	1.90 Max.	2.60 Max.	3.50 Max.	3.60 Max.
Termination bandwidth (b)	0.5±0.20	0.5±0.25	0.5 +0.35/-0.1	0.5 +0.35/-0.1

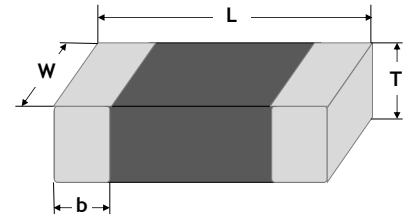

Product Identification:

HSP	1206	SC	012V	0500
Category Code	Size Code	Application Code	Breakdown Voltage Code	Surge Current Code
HSP = High Surge Protection Device	Inch 1206 1210 1812 2220	SC = Super High Current	012V = 12V 024V = 24V 047V = 47V 056V = 56V 075V = 75V 082V = 82V	0500 = 500A 1000 = 1000A 2000 = 2000A 3000 = 3000A 5000 = 5000A 8000 = 8000A

Surge Waveform:

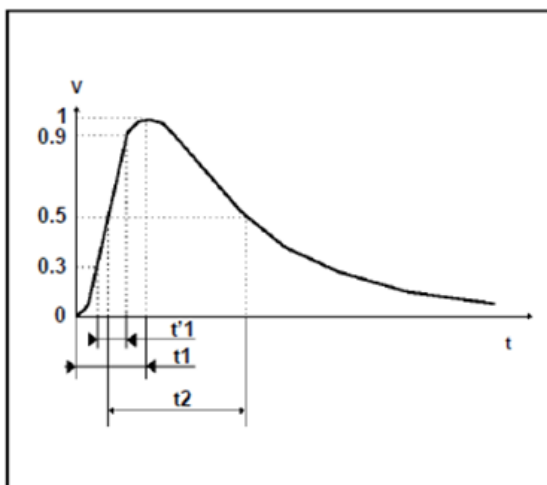

Severity Level	t1 (=1.67t'1)	t2
1	8 µs	20 µs

Fig. 1 8/20 µs surge definition

High Surge Protection Devices Super High Current (SC) Series

Electrical Characteristics:

Part Number	Size	Working Voltage		Breakdown Voltage @1mA (V) ¹	Clamping Voltage (V) ²	Surge Current @ 8/20µs (A) ³
		VAC	VDC			
HSP1206SC012V0500	1206	6	9	12 (12~20)	<25	500
HSP1206SC024V0500	1206	14	18	24 (±10%)	<45	500
HSP1206SC047V0500	1206	30	38	47 (±10%)	<85	500
HSP1206SC075V0500	1206	48	60	75 (±10%)	<100	500
HSP1210SC024V1000	1210	14	18	24 (±10%)	<45	1000
HSP1210SC047V1000	1210	30	38	47 (±10%)	<85	1000
HSP1210SC075V1000	1210	48	60	75 (±10%)	<100	1000
HSP1812SC047V2000	1812	30	38	47 (±10%)	<85	2000
HSP1812SC075V2000	1812	48	60	75 (±10%)	<100	2000
HSP2220SC047V5000	2220	30	38	47 (±10%)	<85	5000
HSP2220SC047V8000	2220	30	38	47 (±10%)	<85	8000
HSP2220SC075V3000	2220	48	60	75 (±10%)	<100	3000

¹ The breakdown voltage was measured at 1 mA current

² The clamping voltage was measured at standard current 1206 (1A), 1210 (2.5A), 1812 (5A) and 2220 (10A)

³ The surge current was tested at 8/20 µs waveform

Part Number	Non-linear Coefficient (α)	Leakage Current (µA)		Capacitance ⁴ @ 1kHz (pF)	Response Time (T _{rise})	Operating Temperature (°C)
		Before Surge Test	After Surge Test			
HSP1206SC012V0500	20	<10	<80	3500	< 1ns	-55 to +125
HSP1206SC024V0500	20	<10	<80	2300		
HSP1206SC047V0500	30	<10	<80	690		
HSP1206SC075V0500	30	<10	<80	300		
HSP1210SC024V1000	20	<15	<80	2300		
HSP1210SC047V1000	30	<10	<80	1550		
HSP1210SC075V1000	30	<10	<80	930		
HSP1812SC047V2000	30	<15	<80	2100		
HSP1812SC075V2000	30	<15	<80	1650		
HSP2220SC047V5000	35	<15	<80	9900		
HSP2220SC047V8000	35	<15	<80	7500		
HSP2220SC075V3000	40	<15	<80	2000		

⁴ The capacitance value only for customer reference, it's not formal specification

High Surge Protection Devices

Super High Network (SN) Series

Features:

- Bidirectional and symmetrical V/I characteristics
- Meet IEC61000-4-5/K21 standard
- Large withstanding surge voltage capability: 4~6KV (@10/700 μ s)
- Excellent low leakage current <10 μ A
- Multilayer construction provides higher power dissipation

Application Fields:

- Telecom equipment RJ45, LAN connector, Ethernet
- Outdoor/Indoor AP/IAD
- Security system IP CAM
- Low voltage power line DC12V, AC24V, PoE
- ADSL/XDSL telecom equipment
- PoE modules
- HUB switch
- VOIP phones
- Other Networks

Shape and Dimensions:

Unit (mm)	1206	1210
Length (L)	3.2 +0.6/-0.2	3.2 +0.6/-0.2
Width (W)	1.6 +0.4/-0.2	2.5 +0.4/-0.2
Thickness (T)	1.90 Max.	2.60 Max.
Termination bandwidth (b)	0.5 \pm 0.20	0.5 \pm 0.25

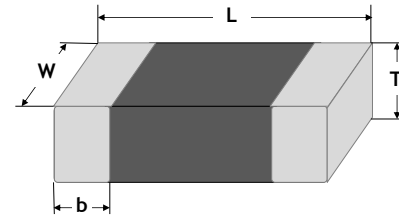

Product Identification:

HSP	1206	SN	012V	4000
<u>Category Code</u>	<u>Size Code</u>	<u>Application Code</u>	<u>Breakdown Voltage Code</u>	<u>Surge Voltage Code</u>
HSP = High Surge Protection Device	Inch (mm) 1206 (3216) 1210 (3225)	SN = Super High Network	012V = 12V 047V = 47V 075V = 75V	4000 = 4kV 6000 = 6kV

Surge Waveform:

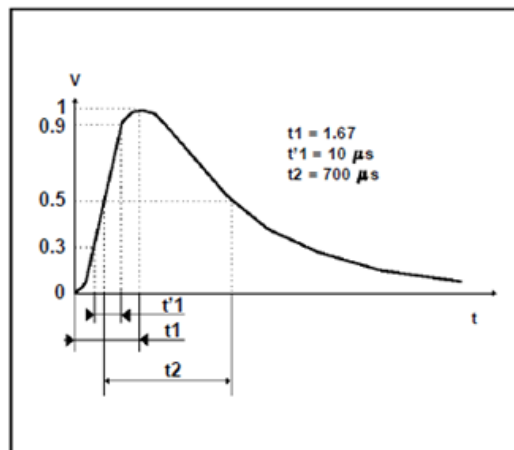

Severity Level	t1 (=1.67t'1)	t2
1	10 μ s	700 μ s

Fig. 1 CCITT 7 10/700 μ s surge definition

High Surge Protection Devices

Super High Network (SN) Series

Electrical Characteristics:

Part Number	Size	Working Voltage		Breakdown Voltage @1mA (V) ¹	Clamping Voltage (V) ²	Surge Current @ 10/700µs (A) ³	Surge Voltage (kV)
		VAC	VDC				
HSP1206SN012V4000	1206	6	9	12 (12~20)	< 30	100	4
HSP1206SN012V6000	1206	6	9	12 (12~20)	< 30	150	6
HSP1210SN047V4000	1210	30	38	47 (±10%)	< 75	100	4
HSP1210SN047V6000	1210	30	38	47 (±10%)	<75	150	6
HSP1210SN075V4000	1210	48	60	75 (±10%)	< 100	100	4
HSP1210SN075V6000	1210	48	60	75 (±10%)	< 100	150	6

¹ The breakdown voltage was measured at 1 mA current.

² The clamping voltage was measured at standard current 1206(1A) and 1210 (2.5A).

³ The surge current was tested at 10/700 µs waveform, Ri=40Ω. Common-mode testing is to test all data lines while the GND.

Part Number	Non-linear Coefficient (α)	Leakage Current (µA)		Capacitance ⁴ @ 1kHz (pF)	Response Time (T _{rise})	Operating Temperature (°C)
		Before Surge Test	After Surge Test			
HSP1206SN012V4000	20	10	80	3200	< 1ns	-55 to +125
HSP1206SN012V6000	20	10	80	3850		
HSP1210SN047V4000	30	10	80	1400		
HSP1210SN047V6000	30	10	80	1670		
HSP1210SN075V4000	30	10	80	1000		
HSP1210SN075V6000	30	10	80	1300		

⁴ The capacitance value only for customer reference, it's not formal specification.

Disclaimer

Specifications are subject to change without notice. AEM products are designed for specific applications and should not be used for any purpose (including, without limitation, automotive, aerospace, medical, life-saving applications, or any other application which requires especially high reliability for the prevention of such defect as may directly cause damage to the third party's life, body or property) not expressly set forth in applicable AEM product documentation. It is the customer's responsibility to validate that a particular product with the properties described in the product specification is suitable for use in a particular application. Warranties granted by AEM shall be deemed void for products used for any purpose not expressly set forth in applicable AEM product documentation. AEM shall not be liable for any claims or damages arising out of products used in applications not expressly intended by AEM as set forth in applicable AEM product documentation. The sale and use of AEM products is subject to AEM terms and conditions of sale. Please refer