

Circuit Protection for Mobile Handheld Devices

The proliferation of mobile handheld devices such as smart phones, e-readers and tablets, their uses in uncontrolled environments and the development of nano-technology makes these devices more sensitive to electrostatic discharge and overcurrent therefore making circuit protection a crucial design requirement. The growing complexity of these devices requires careful consideration when selecting an appropriate overcurrent protection device and transient voltage suppressor. This application note will discuss AEM's complete circuit protection solution for the mobile device platform.

Mobile Handheld Device Failure Mechanisms

The increased probability of mobile handheld device failure has become a major concern to personnel safety, product quality and reliability. Risk of catastrophic damage can be due to number of variables including, incorrect input voltage, transient voltage spikes and the introduction of unregulated low cost battery chargers made by third party manufacturers can pose a serious threat as well. However, there are several techniques to mitigate failures and protect against dangers such as overvoltage and overcurrent.

Electrostatic Discharge

Electrostatic discharge (ESD) is a phenomenon that occurs when two insulators rub together or pull apart. The result is an accumulation of charge that is unbalanced and at rest. When the charged object comes into contact with another object of different potential a

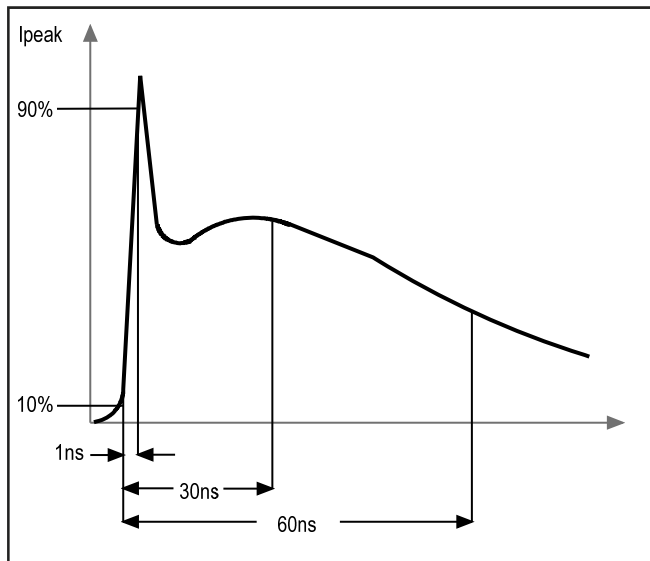

Figure 1. ESD transient waveform per IEC 61000-4-2

transfer of charge occurs. This transfer of charge can produce voltage spikes orders of magnitude greater than normal operating conditions resulting in latent or catastrophic failures. International standard IEC 61000-4-2 accurately replicates an ESD event in the form of a charged person discharging into a system. The resulting ESD event is a very fast transient with rise time of 1ns or less and peak current up to 30A at voltage levels as high as 8kV (Figure 1).

ESD Protection

An ESD suppressor is a device that exhibits non-linear voltage-current characteristics so at low operating voltage the device poses high resistance the circuit func-

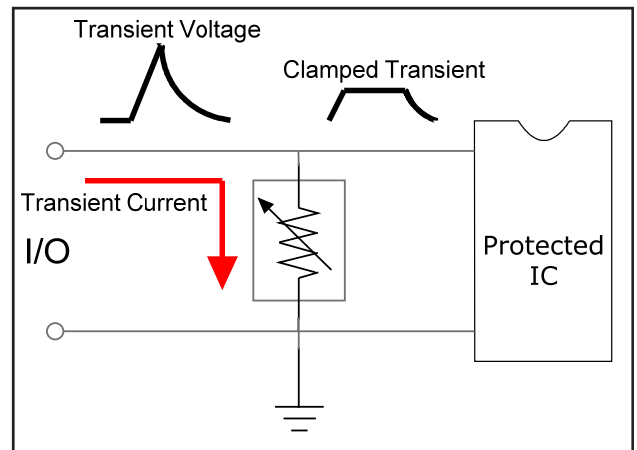

Figure 2. ESD suppression

tions as normal and at high voltage the device becomes low resistance therefore creating a shunt path to ground and clamping the voltage to a tolerable level protecting downstream IC's.

Mobile Device Circuit Protection

The advent of mobile handheld devices such as smart phones and PC tablets the ever increasing demand for high speed data transmission ports such as USB 3.0 and HDMI increases the risk of circuit damage every time the device is connected and disconnected. In addition, the popularity of the touch screen as well as the keypad are also possible entry points for an ESD strike to occur. Implementing a robust circuit protection solution is essential design requirement for mobile handheld devices (Figure 3).

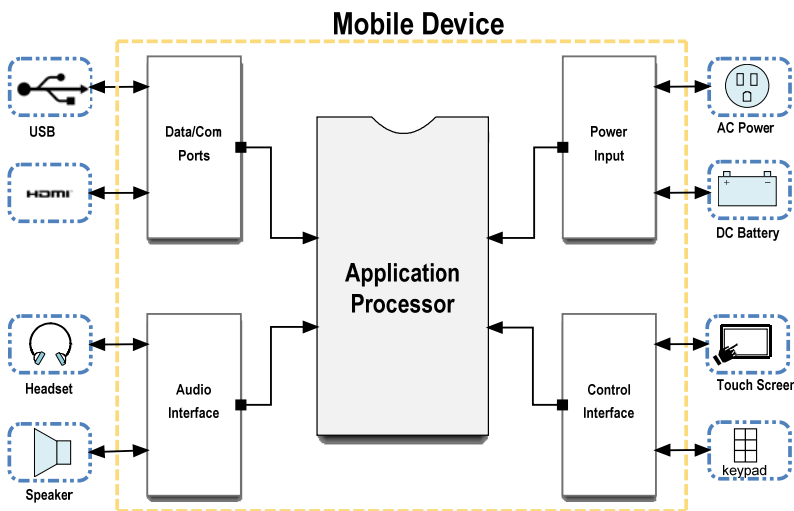

Figure 3. Typical mobile device platform

USB 3.0

USB ports are vulnerable to ESD damage and are therefore required to utilize ESD suppressor to protect the USB controller IC. With data rates of 5Gbit/sec an ESD suppressor with ultra low capacitance needs to be selected to minimize distortion to the data signal. AEM GcDiode® ultra low capacitance ESD suppressor is designed to provide fast response time to an ESD event suppressing harmful transient voltage spikes while maintaining signal integrity. Each data line D+/-, Rx+/-, Tx+/- employ an ESD suppressor safely directing the energy produced by the ESD event to ground. In addition, to achieve a coordinated circuit protection scheme a SolidMatrix® fast acting fuse mounted in series with the Vbus line provides overcurrent protection (Figure 4).

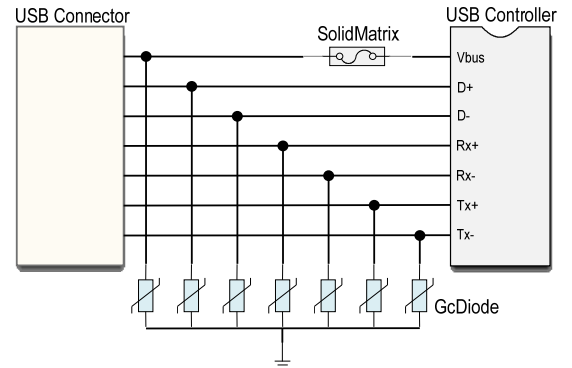

Figure 4. Circuit protection solution for USB 3.0

HDMI 1.3

Every time a HDMI connector is plugged in and out of the HDMI port the threat of ESD exists. The high data rates of HDMI 1.3 compared to previous standards poses serious challenges to designers when selecting a suitable ESD device without compromising performance of the high definition video interface. The GcDiode® nominal capacitance of 0.25pF satisfies HDMI 1.3 protocol with low insertion loss at 3.4Gbit/sec (Figure 5).

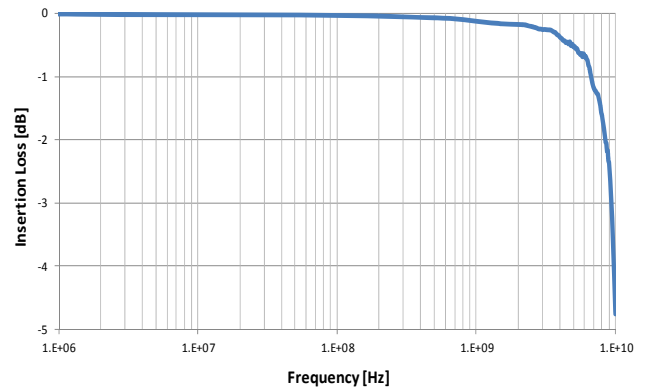

Figure 5. Insertion loss less than -5dB at 10Gbit/sec

By applying the GcDiode® to each of the HDMI data transmission lines adequate ESD protection can be accomplished (Figure 6).

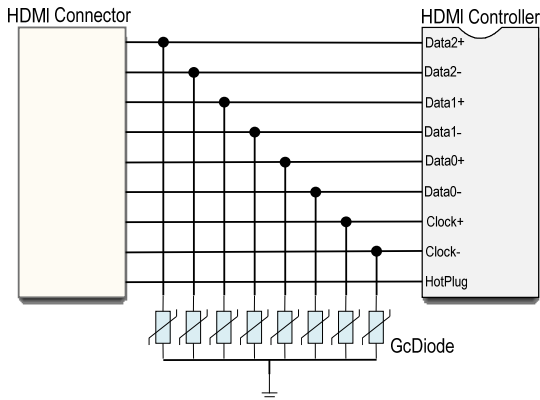

Figure 6. Circuit protection solution for HDMI 1.3

Audio Interfaces

Audio interfaces such as headset, speaker and microphone are also a major concern for ESD because of their exposure to the outside world. Anytime a device is exposed to the outside elements through a port or interface ESD can be introduced through either human touch or contact with another device resulting in serious damage to the internal circuitry. The GcDiode® is an ideal choice for maintaining functionality and performance (Figure 7).

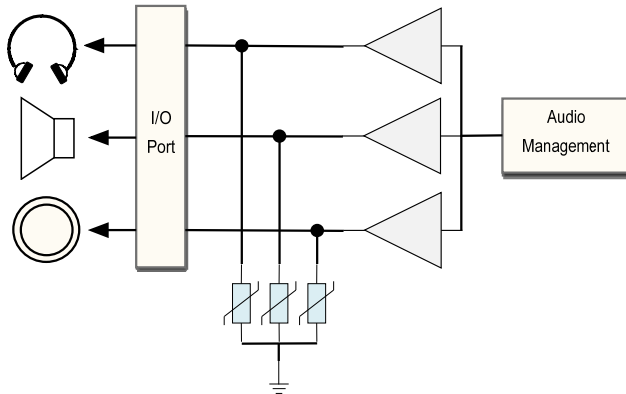

Figure 7. Circuit protection solution for audio interfaces

Control Interfaces

It is very possible for high voltage transients to be coupled into the device through the touch panel or key pad. Neglecting to add ESD suppression devices on the touch panels and key pad lines can result in significant damage to the IC controller.

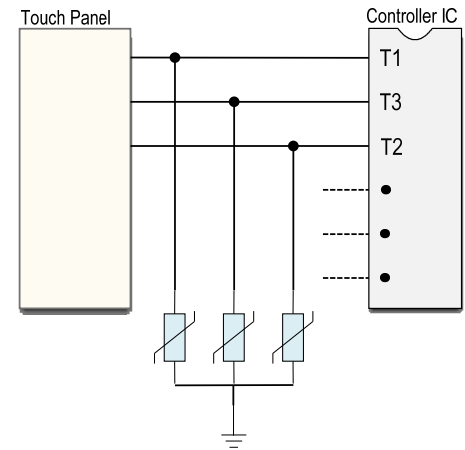

Figure 8. Circuit protection solution for touch panel/key pad (note, actual number of lines may vary depending on application)

Single channel ESD device such as the GcDiode allows board layout flexibility and its ability to withstand multiple ESD strikes makes it a good choice for dissipating the energy produced by an ESD event (Figure 8).

AC Power

Mobile devices AC power adapters are vulnerable to user error such as incorrect input voltage and voltage transients subjecting the user and mobile device to unsafe voltages and currents. In order to mitigate circuit damage and user injury the AC line of the power adapter needs to contain primary overcurrent protection. AEM's AirMatrix wire-in-air AC rated fuse is an ideal solution for primary overcurrent protection on the AC main line (Figure 9).

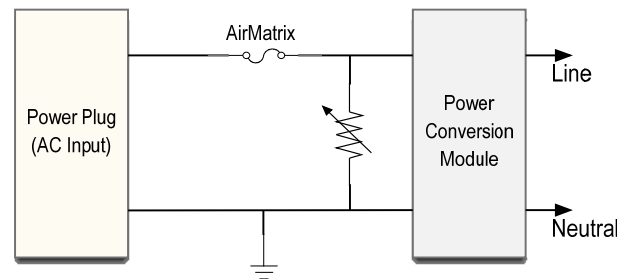

Figure 9. Circuit protection solution for AC power adapters

DC Power

Overcharging due to a faulty or incorrect charger, overheating or an internal fault in the battery management IC are all situations that can potentially cause a short circuit condition in the mobile device battery pack. Accidental shorting of the batteries terminals can also cause a short circuit event and therefore adequate secondary overcurrent protection must be utilized to protect the user from unsafe current levels that can lead to device failure or injury. AEM's SolidMatrix® fast acting fuse compact size and high temperature withstanding capability is an ideal solution for high temperature environments and where available space is limited. In addition, the GcDiode is utilized to prevent ESD damage to the BMS (Figure 10).

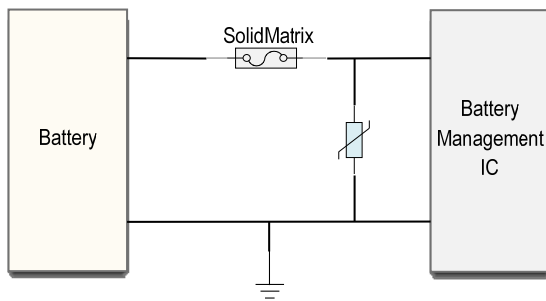

Figure 10. Circuit protection solution for battery pack

LVDS Interface

The Low-Voltage Differential Signaling interface in the mobile device LCD display is susceptible to ESD threats potentially damaging both the driver and receiver circuits. With high data transmission rates an ESD device with low capacitance needs to be considered as to not to distort the high speed signal. In order to reduce the number of components required AEM produces a 4 channel ESD array with combined LC “Pi” type EMI filter on each channel. The MVF series provides level 4 IEC61000-4-2 ESD protection with 25dB attenuation at 800MHz to 2GHz. In addition it's feed through design eliminates the need for unnecessary bends in the traces thus reducing the effect of parasitic inductance (Figure 7).

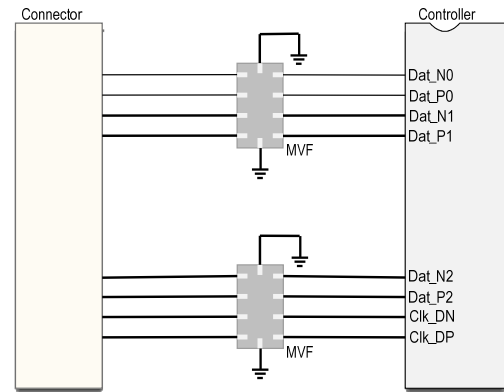

Figure 11. Circuit protection solution for LVDS interface

Conclusion

Circuit protection for mobile device is an essential design requirement for quality, reliability and safety. ESD devices must have low capacitance for high speed data ports to minimize signal attenuation. They must also pose the ability to endure many ESD strikes through out the life time of the mobile device because of their use in uncontrolled environments. Furthermore, surface mount fuses must provide reliable overcurrent protection for the battery pack and AC power supply for safe operation. AEM offers a line of robust ESD suppressor as well as a complete family of fuses with different clear time characteristics for mobile device applications.